



Installation manual

Tumble dryer

D7100, D7135
Type N4...



438905859/US
2018.01.15

CONTACT:

461 Doughty Blvd
Inwood, NY 11096-0338
Tel: 516-371-4400
Fax: 516-371-4204
Email: sales@laundrylux.com

TECH SUPPORT:

Tel: 516-371-0700
Fax: 516-371-4029
Email: techcare@laundrylux.com

PARTS:

Tel: 516-371-2000
Fax: 516-371-4029
Email: parts@laundrylux.com

WARRANTY CLAIMS

Wascomat's Technical Support Staff will honor valid manufacturer's parts warranty claims providing your Wascomat machines are registered for warranty coverage upon installation. If they are not registered, you can validate your warranty claim by providing information about when and where you purchased the Wascomat machine(s), the model and serial number(s). Additional warranty proof may also be required.



WARNING:

FIRE OR EXPLOSION HAZARD

Failure to follow safety warnings exactly could result in serious injury, death or property damage.

Do not store or use gasoline or other flammable vapors and liquids in the vicinity of this or any other appliance.

WHAT TO DO IF YOU SMELL GAS:

- **Do not try to light any appliance.**
- **Do not touch any electrical switch; do not use any phone in your building.**
- **Clear the room, building or area of all occupants.**
- **Immediately call your gas supplier from a neighbor's phone. Follow the gas supplier's instructions.**
- **If you cannot reach your gas supplier, call the fire department.**

Installation and service must be performed by a qualified installer, service agency or the gas supplier.

The above information; "What to do if you smell gas", shall be posted in a prominent location. The information to be posted shall be obtained by consulting with the local gas supplier.

FOR YOUR SAFETY

Do not store or use gasoline or other flammable vapors and liquids in the vicinity of this or any other appliance.

The above information; "For your safety", shall be posted in a prominent location.

Safety

WARNING: The dryer is intended for use only with fabrics that have been washed with water.

WARNING: To avoid fire hazard, do not dry articles containing foam rubber or similarly textured rubberlike materials.

WARNING: ALL OPERATING AND MAINTENANCE PROCEDURES SHOWN ON THE NEXT PAGE OF THIS MANUAL MUST BE FOLLOWED DAILY FOR PROPER OPERATION OF YOUR MACHINE.

MAKE CERTAIN TO KEEP THIS MANUAL IN A SECURE PLACE FOR FUTURE REFERENCE.

PLEASE ENTER THE FOLLOWING INFORMATION AS IT APPEARS ON THE MACHINE(S) DATA PLATE(S).

MACHINE TYPE OR MODEL	
MACHINE SERIAL NUMBER(S)	
ELECTRICAL CHARACTERISTICS: _____ VOLTS, _____ PHASE, _____ HZ.	

Warning: For your safety the information in this manual must be followed to minimize the risk of fire or explosion or to prevent property damage, personnel injury or death.

NOTICE TO: OWNERS, OPERATORS AND DEALERS

IMPROPER INSTALLATION AND INADEQUATE MAINTENANCE, POOR HOUSEKEEPING AND WILLFUL NEGLECT OR BYPASSING OF SAFETY DEVICES MAY RESULT IN SERIOUS ACCIDENTS OR INJURY. TO ASSURE THE SAFETY OF CUSTOMERS AND/OR OPERATORS OF YOUR MACHINE, THE FOLLOWING MAINTENANCE CHECKS MUST BE PERFORMED ON A DAILY BASIS.

1. **Prior to operation of the machine**, check to make certain that all operating instructions and warning signs are affixed to the machine and legible. Missing or illegible ones must be replaced immediately. Be sure you have spare signs and labels available at all times. These can be obtained from your dealer.
2. **Check the door safety interlock, as follows:**
 - a. OPEN THE DOOR of the machine and attempt to start in the normal manner:
For coin-operated models, insert the proper coins to start the machine.
For manually operated models, place the ON-OFF switch in the ON position and press the Start switch.

THE MACHINE(S) MUST NOT START !

- b. CLOSE THE DOOR to start machine operation and, while it is operating, attempt to open the door without exerting extreme force on the door handle. The door should remain locked!
If the machine can start with the door open, or can continue to operate with the door unlocked, the door interlock is no longer operating properly. The machine **must** be placed **out of order** and the interlock immediately replaced.
3. DO NOT UNDER ANY CIRCUMSTANCES ATTEMPT TO BYPASS OR REWIRE ANY OF THE MACHINE SAFETY DEVICES AS THIS CAN RESULT IN SERIOUS ACCIDENTS.
4. **Be sure to keep the machine(s) in proper working order:** Follow **all** maintenance and safety procedures. Further information regarding machine safety, service and parts can be obtained from your dealer.
All requests for assistance must include the model, serial number and electrical characteristics as they appear on the machine identification plate. Insert this information in the space provided on the previous page of this manual.
5. **WARNING:** DO NOT OPERATE MACHINE(S) WITH SAFETY DEVICES BYPASSED, REWIRED OR INOPERATIVE! DO NOT OPEN MACHINE DOOR UNTIL DRUM HAS STOPPED ROTATING!



AVERTISSEMENT :

RISQUE D'INCENDIE OU D'EXPLOSION

Si les avertissements de sécurité ne sont pas suivis à la lettre, cela risque d'entraîner des blessures graves, la mort ou des dégâts matériels.

Ne stockez pas et n'utilisez pas de carburant ou tout autre liquide ou vapeur inflammable à proximité de cet appareil ou de tout autre appareil similaire.

QUE FAIRE SI VOUS SENTEZ DU GAZ:

- **N'allumez aucun appareil.**
- **Ne touchez pas aux interrupteurs électriques. N'utilisez aucun téléphone dans le bâtiment.**
- **Évacuez la pièce, le bâtiment ou la zone.**
- **Contactez immédiatement votre fournisseur de gaz avec le téléphone d'un voisin. Suivez les instructions fournisseur de gaz.**
- **Si vous ne parvenez pas à joindre votre fournisseur de gaz, appelez les pompiers.**

L'installation et l'entretien doivent être effectués par un installateur agréé, un centre d'entretien ou le fournisseur de gaz.

Les informations ci-dessus, « Que faire si vous sentez du gaz », doivent être affichées à un endroit bien visible. Pour savoir quelles informations afficher, consultez votre fournisseur de gaz local.

POUR VOTRE SÉCURITÉ

Ne stockez pas et n'utilisez pas de carburant ou tout autre liquide ou vapeur inflammable à proximité de cet appareil ou de tout autre appareil similaire.

Les informations ci-dessus, « Pour votre sécurité », doivent être affichées à un endroit bien visible.

AVERTISSEMENT : Le séchoir est destiné à être utilisé uniquement avec des tissus qui ont été lavés à l'eau.

AVERTISSEMENT : Pour éviter tout risque d'incendie, ne séchez pas d'articles contenant du caoutchouc mousse ou des matériaux texturés similaires au caoutchouc.

AVERTISSEMENT : TOUTES LES PROCÉDURES DE FONCTIONNEMENT ET DE MAINTENANCE INDICÉES À LA PAGE SUIVANTE DE CE MANUEL DOIVENT ÊTRE SUIVIES QUOTIDIENNEMENT POUR GARANTIR LE BON FONCTIONNEMENT DE VOTRE MACHINE.

GARDEZ CE MANUEL DANS UN ENDROIT SÉCURISÉ POUR RÉFÉRENCE ULTÉRIEURE.

VEUILLEZ ÉCRIRE LES INFORMATIONS SUIVANTES QUI FIGURENT SUR LA OU LES PLAQUES SIGNALÉTIQUES DE LA OU DES MACHINES.

TYPE OU MODÈLE DE MACHINE	
NUMÉRO(S) DE SÉRIE DE LA OU DES MACHINES	
CARACTÉRISTIQUES ÉLECTRIQUES : _____ VOLTS, _____ PHASE, _____ HZ.	

Avertissement : Pour votre sécurité, les informations de ce manuel doivent être respectées afin de minimiser les risques d'incendie ou d'explosion et d'éviter les dommages aux biens, les blessures corporelles ou la mort.

NOTICE POUR : LES PROPRIÉTAIRES, OPÉRATEURS ET REVENDEURS

UNE INSTALLATION INCORRECTE, UNE MAINTENANCE INADÉQUATE, UN MAUVAIS ENTRETIEN MÉNAGER ET LA NÉGLIGENCE VOLONTAIRE OU LE CONTOURNEMENT DES DISPOSITIFS DE SÉCURITÉ PEUVENT ENTRAÎNER DES ACCIDENTS OU DES BLESSURES GRAVES. POUR ASSURER LA SÉCURITÉ DES CLIENTS ET/OU DES OPÉRATEURS DE VOTRE MACHINE, LES CONTRÔLES DE MAINTENANCE SUIVANTS DOIVENT ÊTRE EFFECTUÉS SUR UNE BASE QUOTIDIENNE.

1. **Avant de faire fonctionner la machine**, vérifiez que toutes les instructions de fonctionnement et tous les panneaux d'avertissement sont apposés sur la machine et lisibles. Les informations manquantes ou illisibles doivent être remplacées immédiatement. Assurez-vous de toujours disposer de panneaux et d'étiquettes de remplacement. Vous pouvez les obtenir auprès de votre revendeur.
2. **Vérifiez le verrouillage de sécurité de la porte en procédant comme suit :**
 - a. OUVREZ LA PORTE de la machine et essayez de démarrer la machine de la manière normale :
Pour les modèles à pièces, insérez les pièces nécessaires pour démarrer la machine.
Pour les modèles actionnés manuellement, placez l'interrupteur ON-OFF sur la position ON et appuyez sur l'interrupteur Démarrer.

LA MACHINE NE DOIT PAS DÉMARRER !

- b. FERMEZ LA PORTE pour démarrer la machine et, pendant qu'elle fonctionne, essayez d'ouvrir la porte sans exercer une force trop importante sur la poignée de porte. La porte doit rester verrouillée !
Si la machine peut démarrer avec la porte ouverte, ou peut continuer à fonctionner avec la porte déverrouillée, le dispositif de verrouillage de la porte ne fonctionne plus correctement. La machine **doit** être mise **hors service** et le dispositif de verrouillage doit être remplacé immédiatement.
3. N'ESSAYEZ DANS AUCUNE CIRCONSTANCE DE CONTOURNER OU DE MODIFIER LES DISPOSITIFS DE SÉCURITÉ DE LA MACHINE, CECI POUVANT ENTRAÎNER DES ACCIDENTS GRAVES.
4. **Assurez-vous de garder la ou les machines en bon état de fonctionnement** : Suivez **toutes** les procédures de maintenance et de sécurité. De plus amples informations concernant la sécurité de la machine, la maintenance et les pièces peuvent être obtenues auprès de votre revendeur.
Toutes les demandes d'assistance doivent comporter le modèle, le numéro de série et les caractéristiques électriques indiqués sur la plaque d'identification de la machine. Écrivez ces informations dans l'espace prévu cet effet à la page précédente de ce manuel.
5. **AVERTISSEMENT** : NE FAITES PAS FONCTIONNER LA OU LES MACHINES AVEC DES DISPOSITIFS DE SÉCURITÉ CONTOURNÉS, MODIFIÉS OU INUTILISABLES ! N'OUVREZ LA PORTE DE LA MACHINE QUE LORSQUE LE TAMBOUR A ARRÊTÉ DE TOURNER !



ADVERTENCIA:

PELIGRO DE INCENDIO O DE EXPLOSIÓN

Si no se siguen exactamente las advertencias de seguridad, podrían producirse lesiones graves, la muerte o daños materiales.

No almacene ni utilice gasolina u otros vapores y líquidos inflamables en las cercanías de ésta o de otras máquinas.

QUÉ HACER SI SE HUELE A GAS:

- **No encender ningún aparato.**
- **No tocar interruptores eléctricos y no utilizar ningún teléfono del edificio.**
- **Hacer salir del local, edificio o lugar a todos los presentes.**
- **Llamar inmediatamente al proveedor de gas desde un teléfono vecino. Seguir las instrucciones que se reciban del proveedor de gas.**
- **Si no es posible contactar con el proveedor de gas, llamar a los bomberos.**

La instalación y el mantenimiento han de ser realizados por instaladores cualificados, empresa de servicios o por el proveedor de gas.

La información anterior, "Qué hacer si huele a gas", se deberá publicar en un lugar visible. La información que se va a publicar se deberá obtener tras consultarlo con el proveedor de gas local.

PARA SU SEGURIDAD

No almacene ni utilice gasolina u otros vapores y líquidos inflamables en las cercanías de ésta o de otras máquinas.

La información anterior, "Para su seguridad", se deberá publicar en un lugar visible.

ADVERTENCIA: La secadora ha sido diseñada para su uso únicamente con tejidos que se han lavado con agua.

ADVERTENCIA: Para evitar un riesgo de incendio, no secar artículos que contengan gomaespuma o materiales gomosos con una textura similar.

ADVERTENCIA: TODOS LOS PROCEDIMIENTOS DE MANEJO Y MANTENIMIENTO QUE APARECEN EN LA SIGUIENTE PÁGINA DE ESTE MANUAL DEBERÁN SEGUIRSE DIARIAMENTE PARA EL CORRECTO FUNCIONAMIENTO DE LA MÁQUINA.

ASEGÚRESE DE CONSERVAR ESTE MANUAL EN UN LUGAR SEGURO PARA CONSULTARLO EN EL FUTURO.

INTRODUZCA LA SIGUIENTE INFORMACIÓN TAL Y COMO APARECE EN LAS PLACAS DE DATOS DE LA MÁQUINA.

TIPO O MODELO DE MÁQUINA	
NÚMERO DE SERIE DE LA MÁQUINA	
CARACTERÍSTICAS ELÉCTRICAS: _____ VOLTIOS, _____ FASE, _____ HZ.	

Advertencia: Para su seguridad, la información contenida en el manual ha de seguirse a fin de reducir al mínimo el riesgo de incendio o explosión o para evitar daños materiales, lesiones personales o incluso la muerte.

AVISO PARA: PROPIETARIOS, OPERADORES Y DISTRIBUIDORES

UNA INSTALACIÓN INCORRECTA Y UN MANTENIMIENTO INADECUADO, UNA MALA CONSERVACIÓN Y LA OMISIÓN DELIBERADA O PUENTEADO DE LOS DISPOSITIVOS DE SEGURIDAD PODRÍA RESULTAR EN ACCIDENTES O LESIONES GRAVES. PARA GARANTIZAR LA SEGURIDAD DE LOS CLIENTES Y/O LOS OPERADORES DE SU MÁQUINA, DEBERÁN REALIZARSE LAS COMPROBACIONES DE MANTENIMIENTO SIGUIENTES A DIARIO.

1. **Antes de poner en marcha la máquina**, comprobar que todas las instrucciones de funcionamiento y señales de advertencia están acopladas a la máquina y son legibles. Las que falten o sean ilegibles deberán reemplazarse inmediatamente. Asegúrese de que dispone de signos y etiquetas de repuesto disponibles en todo momento. Puede adquirirlas de su distribuidor.
2. **Compruebe el cierre de seguridad de la puerta, como sigue:**
 - a. ABRA LA PUERTA de la máquina y trate de ponerla en marcha como haría normalmente:
En los modelos que funcionan con monedas, inserte las monedas correspondientes para ponerla en marcha.
En los modelos de funcionamiento manual, coloque el interruptor ON-OFF en la posición ON y pulse el interruptor START.

¡LA MÁQUINA NO DEBE PONERSE EN MARCHA!

- b. CIERRE LA PUERTA para poner en marcha la máquina y, mientras está funcionando, trate de abrir la puerta sin ejercer una fuerza excesiva sobre el asa. ¡La puerta debe mantenerse cerrada!
Si la máquina puede ponerse en marcha con la puerta abierta, o puede continuar funcionando con la puerta desbloqueada, el cierre no está funcionando correctamente. La máquina **debe** dejarse **fuera de servicio** y el cierre debe reemplazarse inmediatamente.
3. NO TRATE, BAJO NINGUNA CIRCUNSTANCIA, DE PUENTEAR O VOLVER A CABLEAR NINGUNO DE LOS DISPOSITIVOS DE SEGURIDAD DE LA MÁQUINA, YA QUE PODRÍAN PRODUCIRSE ACCIDENTES GRAVES.
4. **Asegúrese de mantener las máquinas en funcionamiento:** Siga **todos** los procedimientos de mantenimiento y seguridad. Puede obtener más información sobre la seguridad de la máquina, su mantenimiento y piezas de repuesto de su distribuidor.
Todas las solicitudes de asistencia deben incluir el modelo, número de serie y características eléctricas tal y como aparecen en la placa de identificación de la máquina. Introduzca esta información en el espacio correspondiente en la página anterior de este manual.
5. **ADVERTENCIA:** ¡NO PONGA EN MARCHA LA MÁQUINA CON LOS DISPOSITIVOS DE SEGURIDAD PUENTEADOS, RECLABEADOS O INOPERATIVOS! ¡NO ABRA LA PUERTA DE LA MÁQUINA HASTA QUE EL TAMBOR HAYA DEJADO DE GIRAR!

NOTICE TO INSTALLER

Improper installation of this machine:

- May cause serious damage to the machine.
- May result in other property damage.
- May cause personal injury.
- Will void the manufacturer's warranty.

Connection to line Voltage or over-current protection devices other than those specified on the data plate may result in severe damage to machine components, and will void the manufacturer's warranty.

Refer to complete installation instructions provided in manuals accompanying the machine.

**Contact Wascomat Technical Support with any questions BEFORE installing this machine.
Damage resulting from inadequate installation materials or improper installation techniques will void the manufacturer's warranty.**

Electrical Information

It is your responsibility to have **ALL** electrical connections (including grounding) made by a properly licensed and competent electrician to assure that the electrical installation is adequate and conforms with local and state regulations or codes.

In the absence of such codes, ALL electrical connections, material, and workmanship must **conform** to the applicable requirements of the NATIONAL ELECTRIC CODE ANSI/NFPA NO. 70 or the CANADIAN ELECTRICAL CODE, CSA C22.1 - both the latest edition.

- IMPORTANT:** Failure to comply with these codes or ordinances and/or the requirements stipulated in this manual can result in personal injury or component failure.
- NOTE:** Component failure due to improper installation will **VOID THE WARRANTY**.
- IMPORTANT:** A separate circuit serving each dryer must be provided. The dryer must be connected to copper wire only. **DO NOT** use aluminum wire which could cause a fire hazard.
- NOTE:** The use of aluminum wire will **VOID THE WARRANTY**
- CAUTION:** Label all wires prior to disconnection when servicing controls. Wiring errors can cause improper operation or component failure.

Electrical Service

Steam and gas dryers **ONLY**

IMPORTANT: The dryer must be connected to the electrical supply shown on the data label affixed to the dryer. In the case of 208 VAC or 240 VAC, the supply voltage **must match** the electric service specifications of the data label **exactly**. Wire **must be** properly sized to handle the rated current.

WARNING: 120 VAC, 208 VAC and 240 VAC ARE NOT THE SAME. Any damage done to dryer components due to improper voltage connections will **VOID THE WARRANTY**.



Electric dryers **ONLY**

- IMPORTANT:** ALL electrically heated dryers must be connected to the electric supply service shown on the dryers data label which is affixed to the back side of the control (service) door. The connecting wires must be properly sized to handle the rated current.
- NOTE:** Component failure due to improper voltage application will **VOID THE WARRANTY**.

Gas Information

It is your responsibility to have **ALL** plumbing connections made by a qualified professional to insure that the installation is adequate and conforms with local and state regulations or codes. In the absence of such codes, **ALL** plumbing connections, material, and workmanship must conform to the applicable requirements of **the National Fuel Gas Code ANSI Z223.1** or the **CAN/CGA-B149, INSTALLATION CODES** - both the latest edition.

IMPORTANT: Failure to comply with these codes or ordinances, and/ or the requirements stipulated in this manual, can result in personal injury and improper operation of the dryer.

The dryer **must be** isolated from the gas supply piping system by closing its individual manual shut-off valve during any pressure testing of the gas supply piping system at test pressures equal to or greater than 1/2 psig (3.5 kPa).

IMPORTANT: Failure to isolate or disconnect the dryer from the gas supply as noted can cause irreparable damage to the gas valve and will **VOID THE WARRANTY**.

WARNING: **FIRES or EXPLOSION COULD RESULT.**



Gas Supply

The gas dryer installation must meet the American National Standard, National Fuel Gas Code Z223.1-LATEST EDITION, as well as local codes and ordinances and **must be** done by a qualified professional,

NOTE: Undersized gas piping will result in ignition problems, slow drying, increased use of energy, and can create a safety hazard.

The dryer **must be** connected to the type of heat/ gas indicated on the dryer data label. If this information does not agree with the type of gas available, **do not** operate the dryer. Contact your local dealer or the Wascomat Sales Department.

IMPORTANT: Any burner changes or conversions must be made by a qualified licensed professional.

The input ratings shown on the dryer data label are for elevations of up to 1,999 feet. The adjustment or conversion of the dryer(s) in the field for elevations over 2,000 feet are made by changing each burner orifice. If these conversions are necessary, contact your local dealer or the Wascomat Sales Department.

Natural Gas

If the pressure is too low, ignition failure and/or slow drying times may result. Excessively high supply pressure will result in erratic operation of the gas valves internal pressure regulator. Further information in section: Gas connection.

Propane Gas

Dryers made for use with propane gas have the gas valve pressure regulator blocked open, so that the gas pressure **must be** regulated upstream of the dryer. In accordance with American Gas Association (AGA) standards, a gas pressure regulator, when installed indoors, must be equipped with a vent limiter or a vent line must be installed from the gas pressure regulator vent to the outdoors. The water column pressure **must be** regulated at the source (propane tank), or an external regulator must be added to each dryer. Further information in section: Gas connection.

Piping/Connections

The dryer is provided with a 1/2" N.P.T. inlet pipe connection extending out the rear area or through the top of the dryer. For ease of servicing, the gas supply line of each dryer should have its own shut-off valve.

The size of the gas supply line (header) will vary depending on the distance this supply line travels from the gas meter or, in the case of propane gas, the supply tank, the number of tees, other gas-operated appliances, etc. Specific information regarding supply line size should be determined by the gas supplier.

NOTE: Undersized gas supply piping can create a low or inconsistent gas pressure which will result in erratic operation of the burner ignition system.

Consistent gas pressure is essential at **ALL** gas connections. It is recommended that a 3/4- inch pipe gas loop be installed in the supply line serving the bank of dryers. An in-line pressure regulator **must be** installed in the gas supply line (header) if (natural) gas line pressure exceeds 12-inches water column pressure.

IMPORTANT: The information regarding the settings of the water column pressure for Natural gas dryers and Propane gas dryers is found in section: Gas connection. The pressure is required at the gas valve pressure tap of each dryer for proper and safe operation.

A 1/8" N.P.T. plugged tap, accessible for test gauge connection, **must be** installed in the main gas supply line immediately upstream of each dryer.

IMPORTANT: Pipe joint compounds that resist the action of natural gas and propane gas **MUST BE** used.

WARNING: Test **ALL** connections for leaks by brushing on a soapy water solution (liquid detergent also works well). **NEVER TEST FOR GAS LEAKS WITH AN OPEN FLAME.**

ALL components / materials **must conform** to NATIONAL FUEL GAS CODE specifications. It is important that gas pressure regulators meet applicable pressure requirements and that gas meters are rated for the total amount of appliance BTU's being supplied.

Contents

Contents

1	Safety Precautions	19
1.1	General safety information.....	21
1.2	Commercial use only.....	21
1.3	Symbols.....	21
2	Technical data.....	22
2.1	Drawing	22
2.1.1	Standard.....	22
2.1.2	Sliding door and tilt.....	23
2.1.3	Sliding door.....	24
2.2	Motor specifications	24
2.3	Technical data	25
2.3.1	D7100	25
2.3.2	D7135	26
2.4	Connections	26
2.4.1	D7100	26
2.4.2	TD135	26
3	Setup	27
3.1	Siting	27
3.2	Unpacking.....	27
3.3	Mechanical installation	29
3.4	Set up machine with tilting function.....	30
4	Evacuation system	31
4.1	Air principle	31
4.2	Fresh air.....	31
4.3	Exhaust duct	32
4.4	Shared exhaust duct	33
4.5	Exhaust dimensioning	34
5	Steam connection	35
6	Gas connection	36
6.1	General.....	36
6.2	Gas installation.....	36
6.3	Table of pressure and adjustment.....	36
6.4	Nozzles sizes depending on altitudes	37
6.5	Test run.....	37
6.6	Converting instructions.....	38
6.7	Converting from natural gas to propane gas.....	39
6.8	Data label.....	39
7	Electrical connection.....	40
7.1	Electrical installation	40
7.2	Internal connection.....	40
7.3	Electrical connections	41
8	Installation of heating unit.....	42
8.1	Gas heating unit installation	42
8.2	Electric heating unit installation	48
8.3	Steam heating unit installation	55
8.4	Mounting equipment for sliding door.....	64
9	Installation of tilting unit.....	66
9.1	Contents	66
9.2	Installation.....	67
10	Function check.....	76
11	Adapter for direct fresh-air intake.....	78

The manufacturer reserves the right to make changes to design and component specifications.

1 Safety Precautions

- The machine is not to be used if industrial chemicals have been used for cleaning.
- Do not dry unwashed items in the machine.
- Items that have been soiled with substances such as cooking oil, acetone, alcohol, petrol, kerosene, spot removers, turpentine, waxes and wax removers should be washed in hot water with an extra amount of detergent before being dried in the machine.
- Items such as foam rubber (latex foam), shower caps, waterproof textiles, rubber backed articles and clothes or pillows fitted with foam rubber pads should not be dried in the machine.
- Fabric softeners or similar products should be used as specified by the fabric softener instructions.
- The final part of a drying cycle occurs without heat (cool down cycle) to ensure that the items are left at a temperature that ensures that the items will not be damaged.
- Remove all objects from pockets such as lighters and matches.
- **WARNING.** Never stop the machine before the end of the drying cycle unless all items are quickly removed and spread out so that the heat is dissipated.
- Adequate ventilation has to be provided to avoid the back flow of gases into the room for appliances burning other fuels, including open fires.
- Exhaust air must not be discharged into a flue which is used for exhausting fumes from appliances burning gas or other fuels.
- The machine must not be installed behind a lockable door, a sliding door or a door with a hinge on the opposite side to that of the machine in such a way that a full opening of the machine is restricted.
- If the machine has a lint trap this has to be cleaned frequently.
- The lint must not be accumulated around the machine.
- **DO NOT MODIFY THIS APPLIANCE.**
- Servicing shall be carried out only by authorized personnel.
- Only authorized spare parts shall be used.
- When performing service or replacing parts, the power must be disconnected.

- When the power is disconnected, the operator must see that the machine is disconnected (that the plug is removed and remains removed) from any point to which he has access. If this is not possible, due to the construction or installation of the machine, a disconnection with a locking system in the isolated position shall be provided.
- In accordance with the wiring rules: mount a multi-pole switch prior to the machine to facilitate installation and service operations.
- The openings in the base, shall not be obstructed by a carpet.
- Maximum mass of dry cloth: D7100: 45 kg / 99 lbs, D7135: 60 kg / 132 lbs.
- A-weighted emission sound pressure level at working stations: < 70 dB(A).

Gas heated tumble dryer:

- Before installation, check that the local distribution conditions, nature of gas and pressure and the adjustment of the appliance are compatible.
- The machine is not to be installed in rooms containing cleaning machines with perchloroethylene, TRICHLOROETHYLENE or CHLOROFLUOROCONTAINING HYDROCARBONS as cleaning agents.
- If you can smell gas:
 - Do not switch on any equipment
 - Do not use electrical switches
 - Do not use telephones in the building
 - Evacuate the room, building or area
 - Contact the person responsible for the machine
- Additional requirements for the following countries; AT, BE, BG, HR, CY, CZ, DK, EE, FI, FR, DE, GR, HU, IS, IE, IT, LV, LT, LU, MT, NL, NO, PL, PT, RO, SK, SI, ES, SE, CH, TR, UK:
 - CAUTION: This appliance shall not be installed where the public has access.
- Additional requirements for other countries:
 - This appliance is not intended for use by persons (including children) with reduced physical, sensory or mental capabilities, or lack of experience and knowledge, unless they have been given

supervision or instruction concerning use of the appliance by a person responsible for their safety. Children should be supervised to ensure that they do not play with the appliance.



1.1 General safety information

In order to prevent damage to the electronics (and other parts) that may occur as the result of condensation, the machine should be placed in room temperature for 24 hours before being used for the first time.

1.2 Commercial use only

The machine/machines covered by this manual is/are made for commercial and industrial use only.

1.3 Symbols

	Caution
	Caution, hot surface
	Read the instructions before using the machine

2 Technical data

2.1 Drawing

2.1.1 Standard

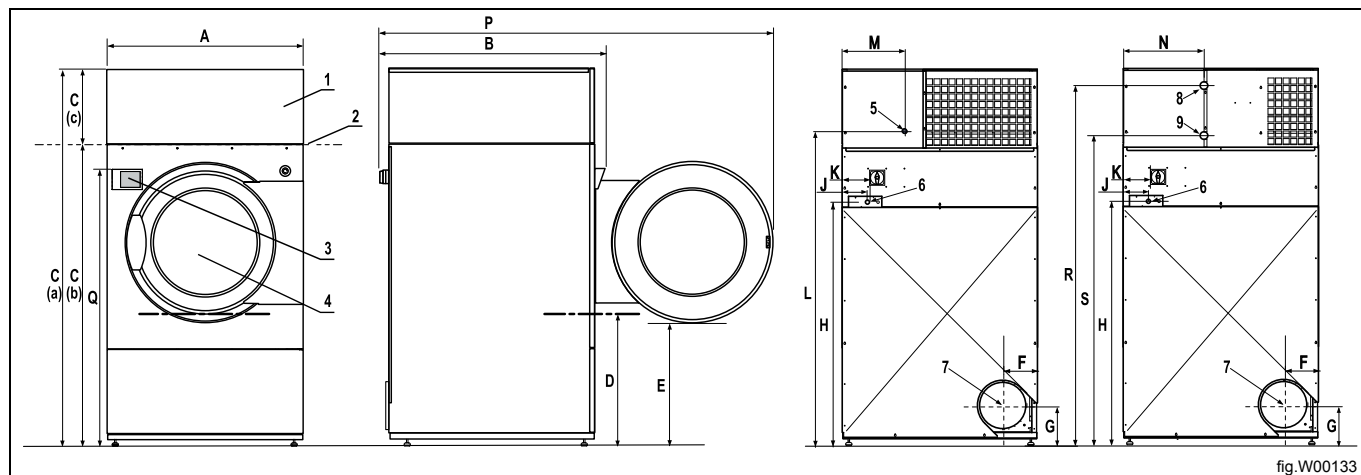

fig.W00133

1	Heating unit
2	Delivery height, excl. 100 mm / 3 15/16 inch packaging
3	Operating panel
4	Door opening, \varnothing 940 mm / \varnothing 37 inch
5	Gas connection
6	Electric connection
7	Exhaust duct
8	Steam inlet
9	Steam return

mm inch	A	B	C (a)	C (b)	C (c)	D	E	F
D7100	1290 50 13/ 16	1295 51	2465 97 1/16	1965 77 3/8	500 19 11/ 16	850 33 7/16	790 31 1/8	230 9 1/16
D7135	1290 50 13/ 16	1485 58 7/16	2465 97 1/16	1965 77 3/8	500 19 11/ 16	850 33 7/16	790 31 1/8	230 9 1/16

mm inch	G	H	J	K	L	M	N	P
D7100	245 9 5/8	1590 62 5/8	165 6 1/2	180 7 1/16	2055 80 7/8	410 16 1/8	530 20 7/8	2400 94 1/2
D7135	245 9 5/8	1590 62 5/8	165 6 1/2	180 7 1/16	2055 80 7/8	410 16 1/8	530 20 7/8	2590 101 15/ 16

mm inch	Q	R	S
D7100	1868 73 9/16	2350 92 1/2	2060 81 1/8
D7135	1868 73 9/16	2350 92 1/2	2060 81 1/8

2.1.2 Sliding door and tilt

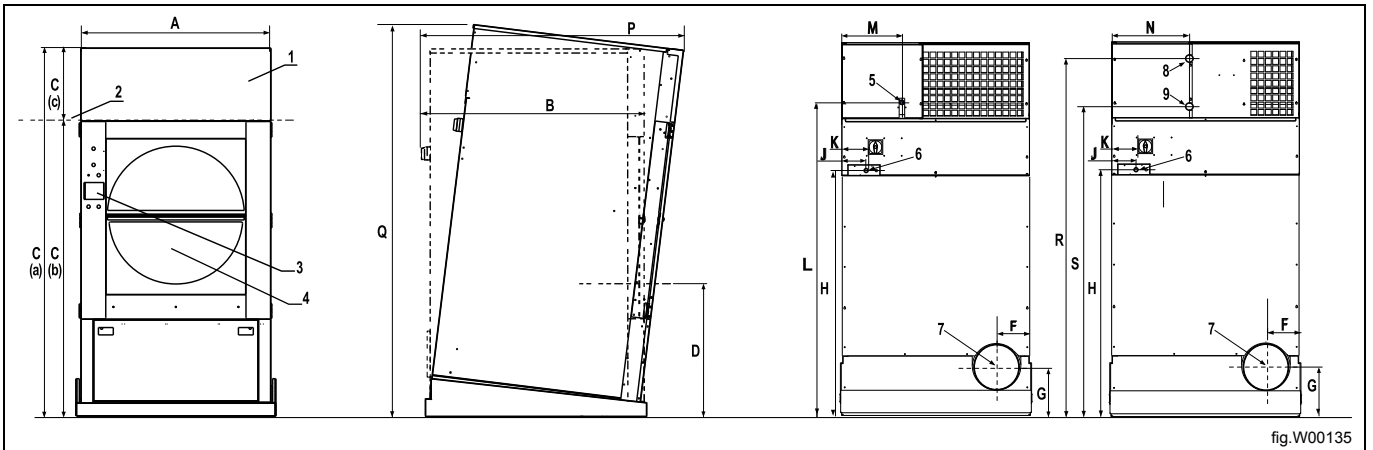

fig.W00135

1	Heating unit
2	Delivery height, excl. 100 mm / 3 15/16 inch packaging
3	Operating panel
4	Door opening, \varnothing 940 mm / \varnothing 37 inch
5	Gas connection
6	Electric connection
7	Exhaust duct
8	Steam inlet
9	Steam return

mm inch	A	B	C (a)	C (b)	C (c)	D	E	F
D7100	1320 51 15/ 16	1295 51	2550 100 3/8	2045 80 1/2	500 19 11/ 16	930 36 5/8	—	230 9 1/16
D7135	1320 51 15/ 16	1485 58 7/16	2550 100 3/8	2045 80 1/2	500 19 11/ 16	930 36 5/8	—	230 9 1/16

mm inch	G	H	J	K	L	M	N	P
D7100	330 13	1670 65 3/4	165 6 1/2	180 7 1/16	2130 83 7/8	410 16 1/8	530 20 7/8	1540 60 5/8
D7135	330 13	1670 65 3/4	165 6 1/2	180 7 1/16	2130 83 7/8	410 16 1/8	530 20 7/8	1740 68 1/2

mm inch	Q	R	S
D7100	2660 104 3/4	2425 95 1/2	2130 83 7/8
D7135	2680 105 1/2	2425 95 1/2	2130 83 7/8

2.1.3 Sliding door

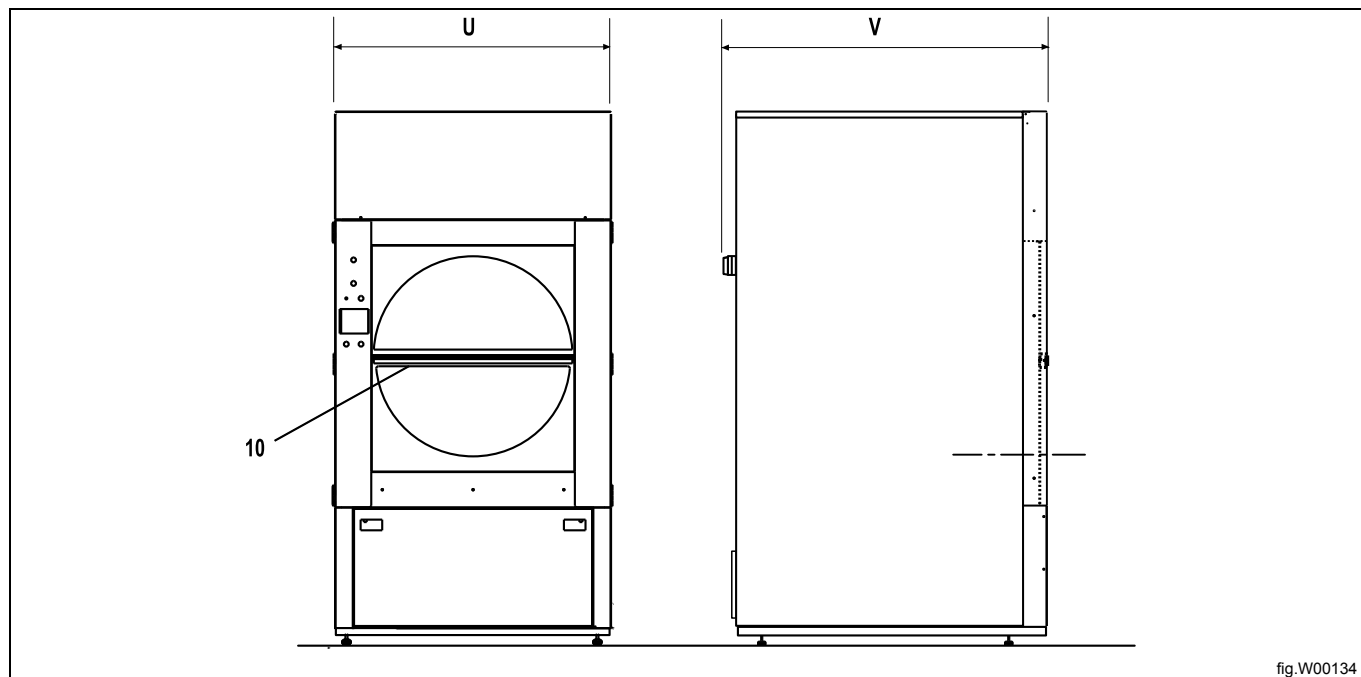

10 | Door opening with sliding door, \varnothing 940 mm / \varnothing 37 inch

mm inch	U	V
D7100	1314 51 3/4	1290 50 13/ 16
D7135	1314 51 3/4	1480 58 1/4

2.2 Motor specifications

		D7100	D7135
Blower motor 3-phase, effect	kW	1.1	1.1
50 Hz	rpm	2800	2800
60 Hz	rpm	3400	3400
Drum motor 3-phase, effect	kW	1.5	1.5
50 Hz	rpm	1440	1440
60 Hz	rpm	1730	1730

2.3 Technical data

2.3.1 D7100

Weight, standard machine	kg lbs	440 970
Weight, with sliding door	kg lbs	494 1087
Weight, with sliding door and tilt	kg lbs	546 1203
Weight, heating unit, gas	kg lbs	39 86
Weight, heating unit, steam	kg lbs	50 110
Weight, heating unit, electric	kg lbs	42 93
Weight, tilting unit	kg lbs	66 146
Drum volume	litres ft ³	900 31.8
Drum diameter	mm inch	1240 48 13/16
Drum depth	mm inch	770 30 5/16
Drum speed	rpm	38
Rated capacity, filling factor 1:20 (Max. load)	kg lbs	45 100
Heating: Electric	kW	48/60
Heating: Steam at 100 psi	kW	82
Heating: Gas	kW	64
Air consumption	m ³ /h cu.ft./min	2300 1354
Pressure drop	Max. Pa Max. psi	100 0.015
A-weighted emission sound pressure level at working stations	dB(A)	< 70

2.3.2 D7135

Weight, standard machine	kg lbs	470 1036
Weight, with sliding door	kg lbs	524 1153
Weight, with sliding door and tilt	kg lbs	576 1270
Weight, heating unit, gas	kg lbs	46 101
Weight, heating unit, steam	kg lbs	50 110
Weight, heating unit, electric	kg lbs	42 93
Weight, tilting unit	kg lbs	66 146
Drum volume	litres ft ³	1200 42.4
Drum diameter	mm inch	1240 48 13/16
Drum depth	mm inch	1000 39 3/8
Drum speed	rpm	38
Rated capacity, filling factor 1:20 (Max. load)	kg lbs	60 132
Heating: Electric	kW	60/72
Heating: Steam at 100 psi	kW	82
Heating: Gas	kW	82
Air consumption, max.	m ³ /h cu.ft./min	3000 1765
Pressure drop	Max. Pa Max. psi	100 0.015
A-weighted emission sound pressure level at working stations	dB(A)	< 70

2.4 Connections**2.4.1 D7100**

Air outlet	∅ mm	315
Gas connection	1"	ISO 7/1-R1
Steam inlet/outlet		ISO 228/1-G1

2.4.2 TD135

Air outlet	∅ mm ∅ inch	315 12
Gas connection	1"	ISO 7/1-R1
Steam inlet/outlet		ISO 228/1-G1

3 Setup

3.1 Siting

Place the machine in its place before unpacking it.

When unpacking the machine, handle it with care.

The machine should be positioned so that there is plenty of room for working, both for the user and service personnel.

The figure shows minimum distance to a wall and/or other machines.

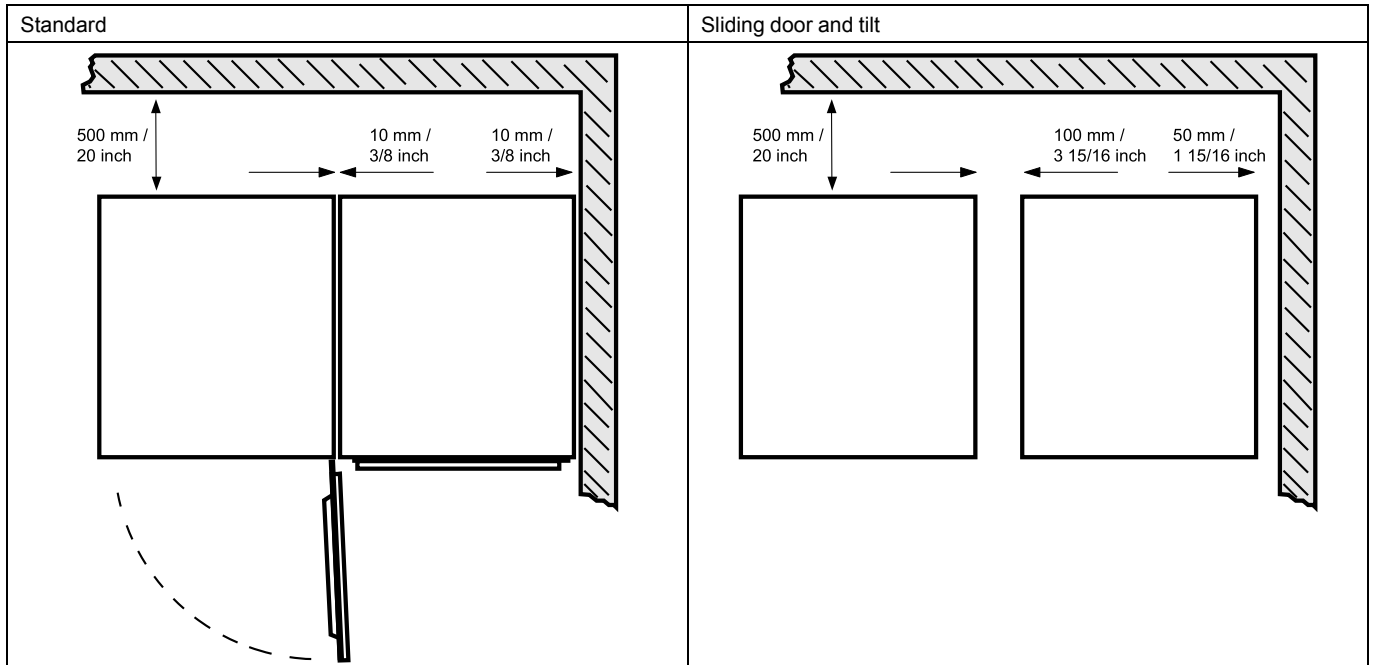

3.2 Unpacking

Note!

Two persons are recommended for the unpacking.

Demount the back panels and the filter door.

Knock the two wood boards loose with a hammer, one in the front and one in the back.

Demount the four screws holding the bars.



fig.W00138

Lift the machine with a pallet truck or a fork-lift truck and remove the bars.
Mount the four feet in the bottom bearers.



fig.W00139

Remove steel sections and the remainder from the transportation pallet.

D7135 only: When the pallet truck or the fork-lift truck is removed the two steel sections are disengaged.

Transport securities

During transport the transmission is secured.

Remove the transportation securing (A) by cutting the strips.

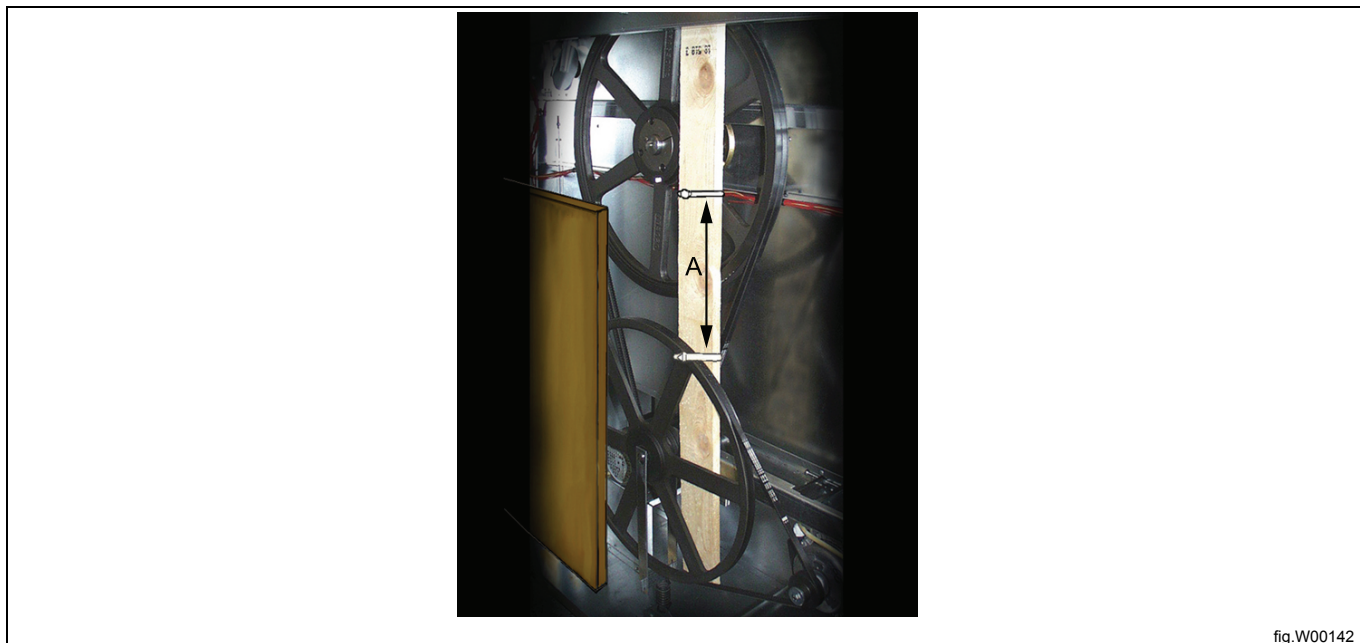
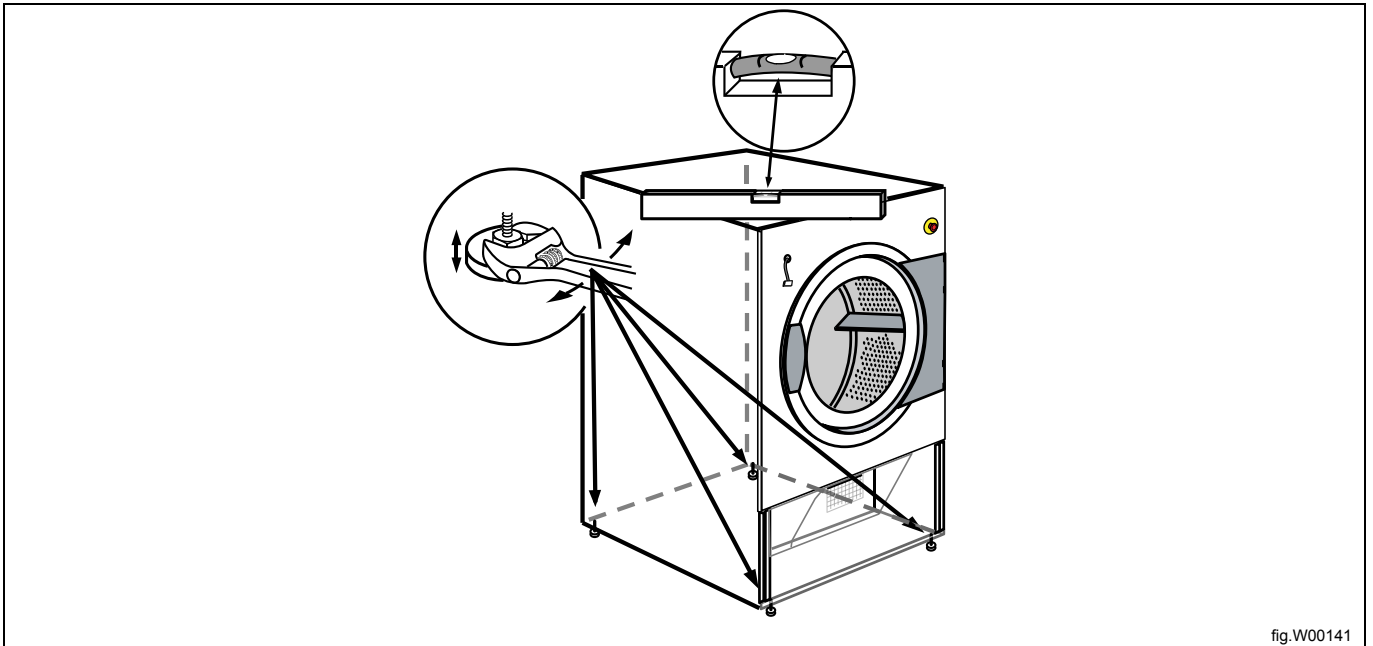

fig.W00142

3.3 Mechanical installation

Level the machine with the feet of the machine. (The height adjustment must be as low as possible).

The maximum height adjustment of the feet is 70 mm / 2 3/4 inch and is only to be used cautiously while removing lifting truck or fork truck.



Heating unit

The heating unit is to be mounted on top of the machine.

During transport the top panel for the heating unit is placed on top of the machine.

Equally during transport the two side panels and the bracing bar (A) are placed in the back of the machine.



3.4 Set up machine with tilting function

Flexible piping connection, gas heated machines

Due to the tilting function gas pipe (A) must end 300 mm / 11 13/16 inch before the machine and the last piece of it must be flexible eg. an approved 600 mm / 23 5/8 inch gas hose.

Flexible piping connection, steam heated machines

Due to the tilting function the steam hoses must have an excessive length of 300 mm / 11 13/16 inch.

Outlet duct, all heating types

Due to the tilting function the outlet duct (B) must have a flexible hose 200 mm / 7 7/8 inch before the machine.

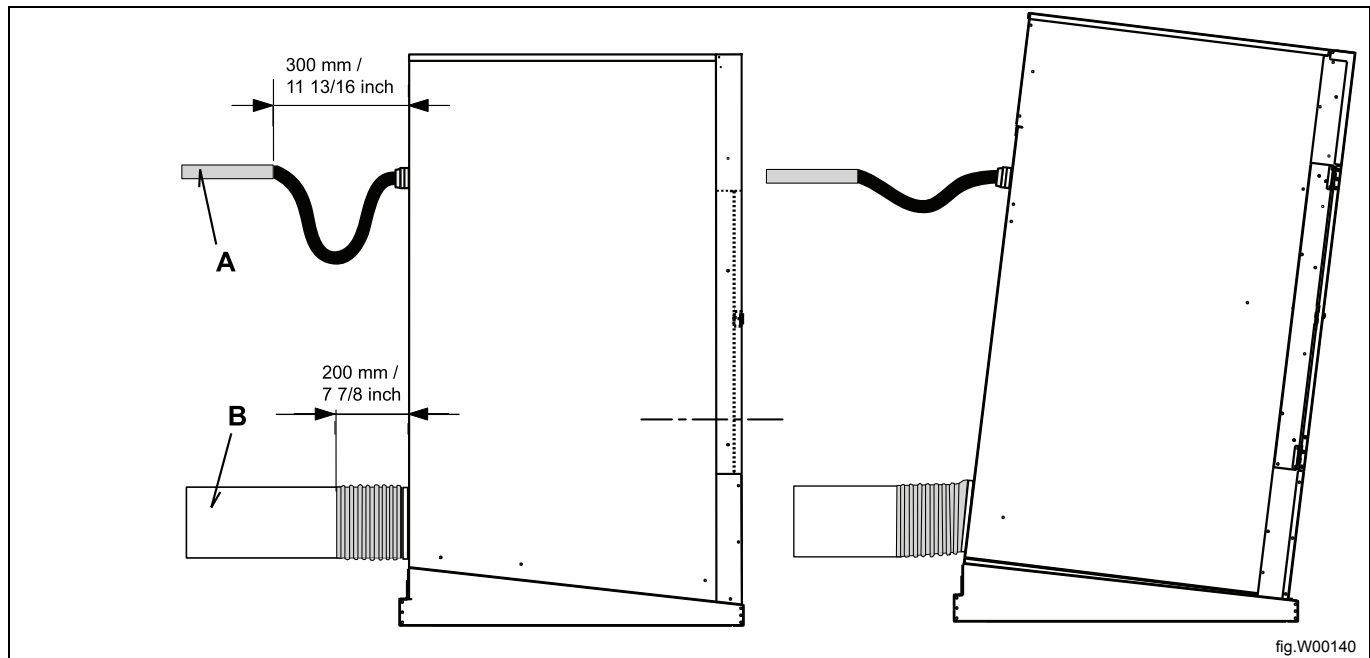

4 Evacuation system

4.1 Air principle

The blower creates low pressure in the machine, drawing air into the cylinder via the heating unit.

The heated air passes through the garments and the cylinder vents.

The air then flows out through a lint filter positioned immediately below the drum. After this, the air is evacuated through the blower and exhaust system.

Note!

It is very important that the machine gets enough fresh air in order to get the best drying result.

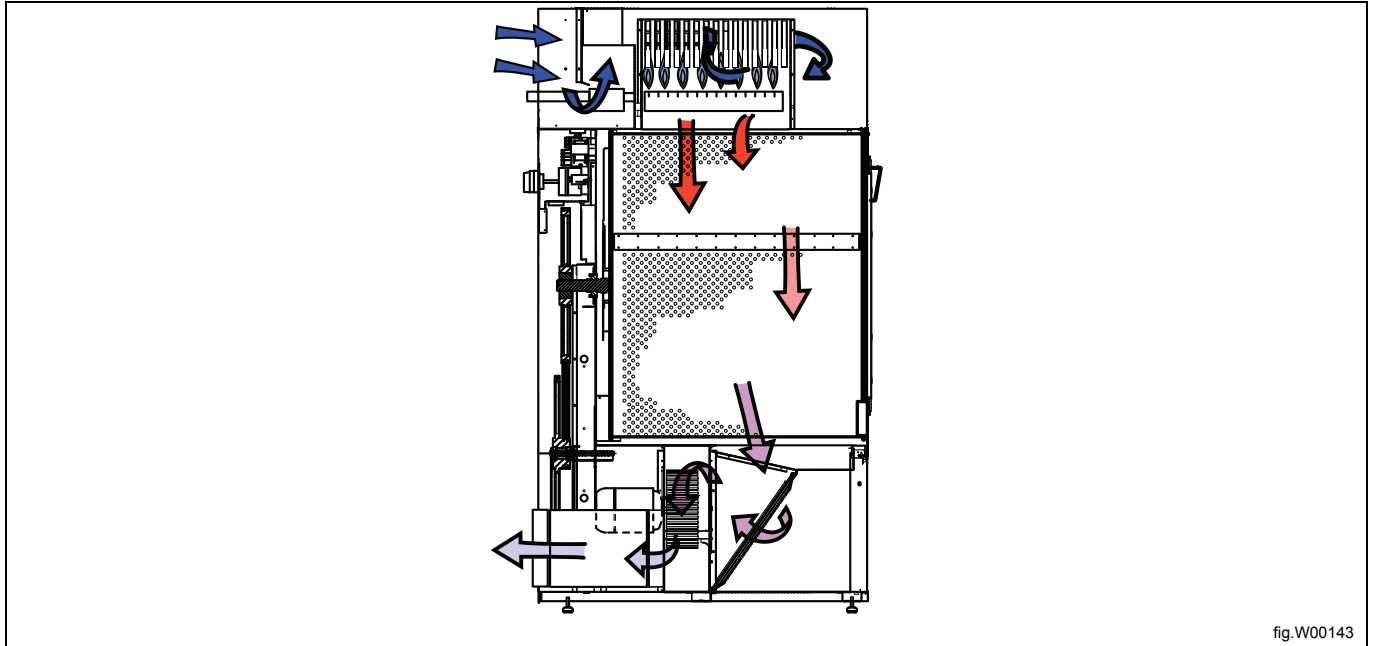

fig.W00143

4.2 Fresh air

For maximum efficiency and the shortest possible drying time, it is important to ensure that fresh air is able to enter the room from the outside in the same volume as that blown out of the room.

To avoid draught in the room it is important to place the air inlet behind the machine.

The area of the air inlet opening is recommended to be five times the size of the exhaust pipe area. The area of the inlet opening is the area through which the air can flow without resistance from the grating/slatted cover.

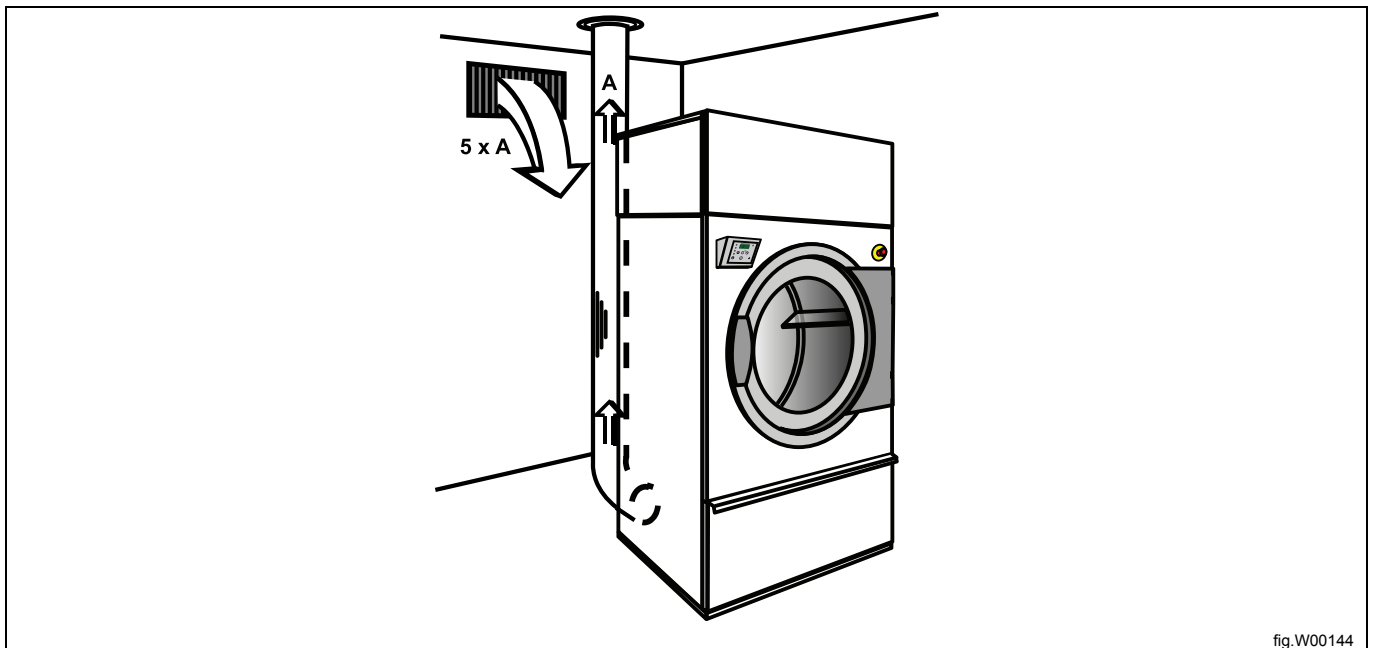

fig.W00144

The resistance in the grating/slats on the air inlet cover plate should not exceed 10 Pa (0.1 mbar).

Note!

Gratings/slatted covers often block half of the total fresh air vent area. Remember to take this into account.

4.3 Exhaust duct

- Only rigid or flexible metal duct should be used for exhausting.
- Plastic ducting is not to be used.
- Recommended material for exhaust is galvanized steel.
- The duct is not to be assembled with screws or other fastening means that extend into the duct and catch lint.
- The exhaust air should not be vented into a wall, a ceiling, or a concealed space of building.
- The exhaust duct must lead clear of the building as condensation may cause frost damage to the building.
- The exhaust duct must lead to the outdoors.
- The exhaust duct must be placed in such a way that it is protected on the outside.
- The exhaust duct must be smooth on the inside (low air resistance).
- The exhaust duct must have gentle bends.

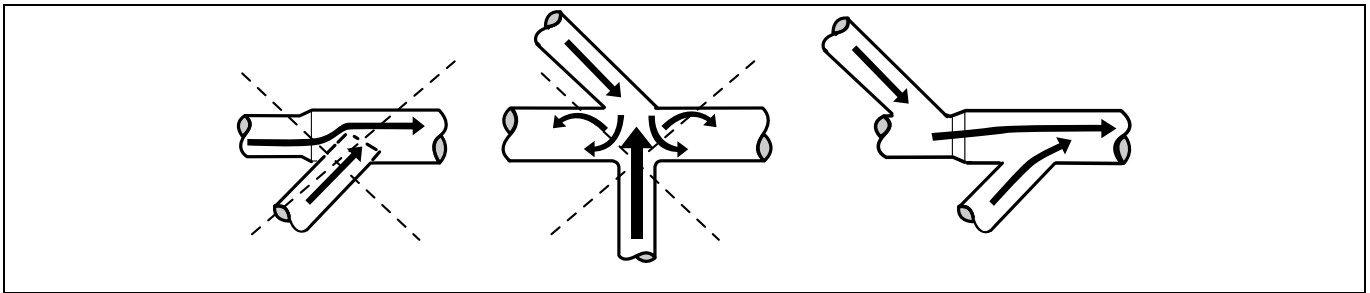

The machine is designed to work with 25 m / 98 1/4 inch outlet pipe and two 90 degree bends.

Each bend is equal to 2.5 m / 98 7/16 inch. If more than two bends is needed the length should maximum be shortened with 2.5 m / 98 7/16 inch per bend.

Exhaust illustrations

The end of the exhaust duct must never be exposed to wind pressure.

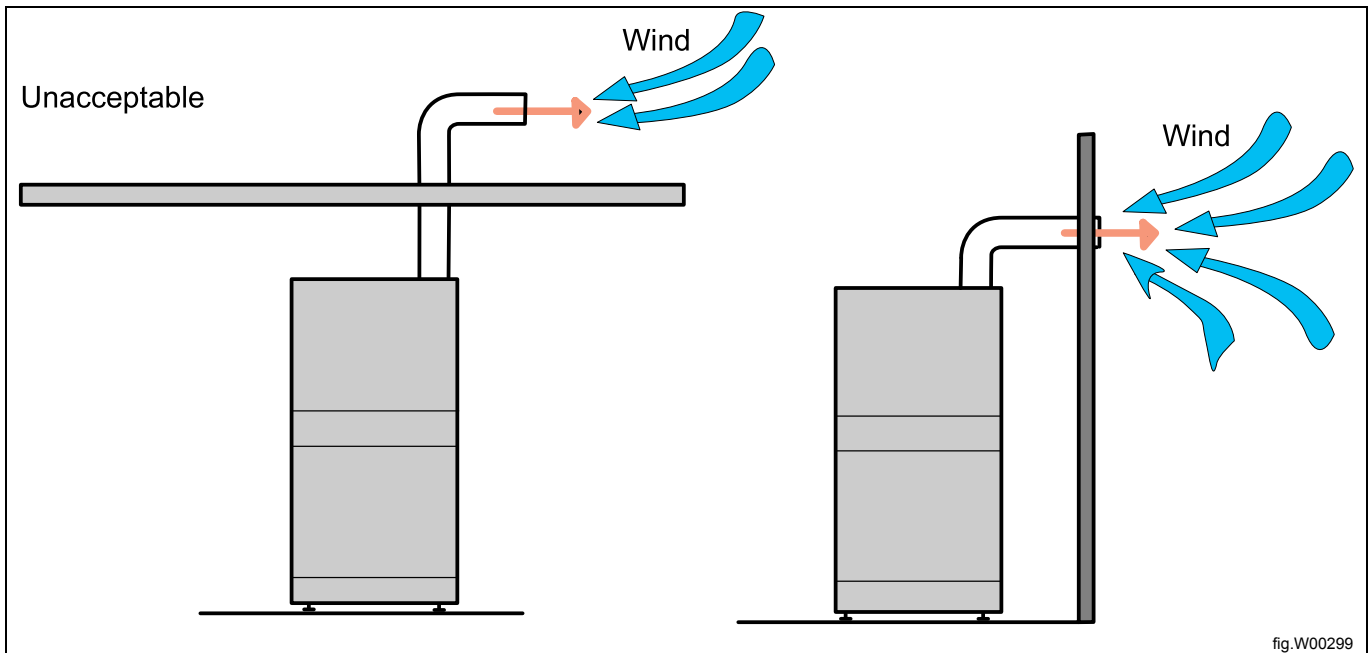
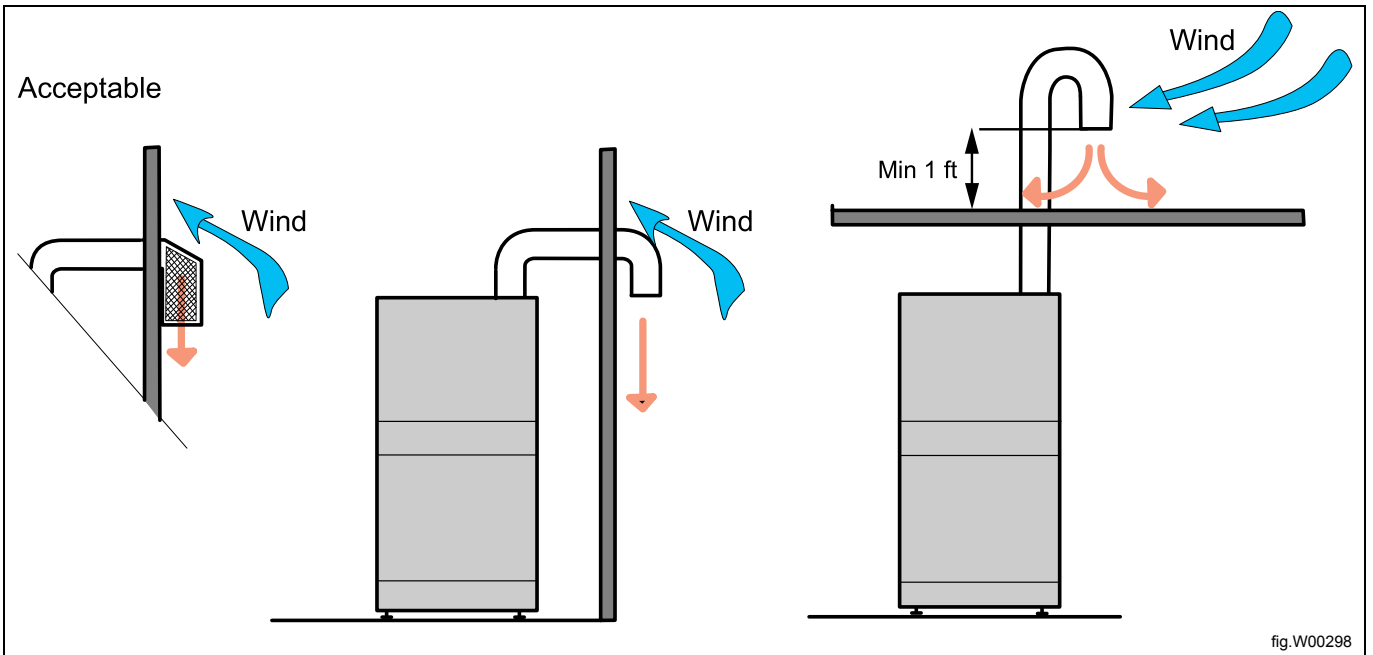

fig.W00299



4.4 Shared exhaust duct



It is recommended that each machine is connected to a separate exhaust duct.



When several machines shall use the same exhaust duct the exhaust duct must increase after each machine.

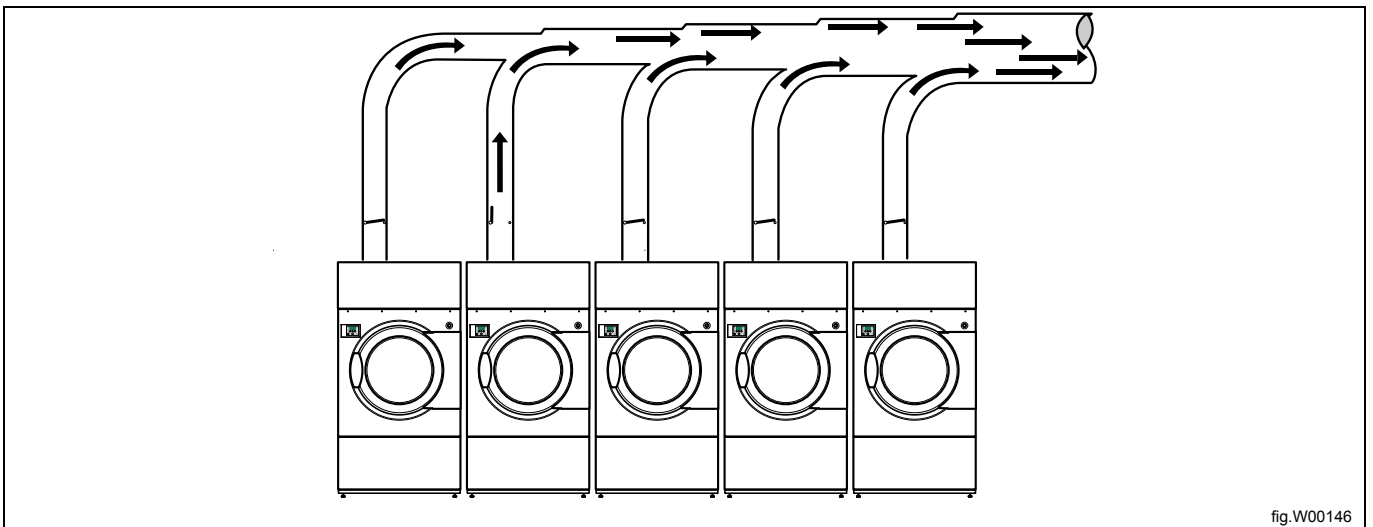

Number of machines		1	2	3	4	5	6	7	8	9	10
Exhaust duct	ø mm	315	500	630	630	800	800	1000	1000	1000	1000
	ø inch	12	18	22	26	28	32	34	36	38	40
Recommended area of fresh air intake	m ²	0.39	0.98	1.56	1.56	2.51	2.51	3.93	3.93	3.93	3.93
	ft ²	4	8.8	13.2	18.4	21.3	27.9	31.5	35.3	39.4	43.6
Minimum area of fresh air intake	m ²	0.27	0.54	0.81	1.08	1.35	1.62	1.89	2.16	2.43	2.7
	ft ²	2.9	5.8	8.7	11.6	14.5	17.4	20.3	23.2	26.1	29



The exhaust duct diameter must not be reduced.

4.5 Exhaust dimensioning

It is important that the machine has correct air volume compared to each machines power.

If the air flow is smaller or larger this will result in a longer drying period.

If the outlet pipe is long or the ventilation is not properly designed we recommend to clean the outlet pipes periodically.

The exhaust pipes shall be short in order for the machine to work in the best way.

All cover panels must be mounted in order for the machine to work in the best way.

5 Steam connection

Note!

The steam supply must be cut off and must not be under pressure.

Steam 3-10 bar absolute pressure (130 - 180°C / 266–356°F).

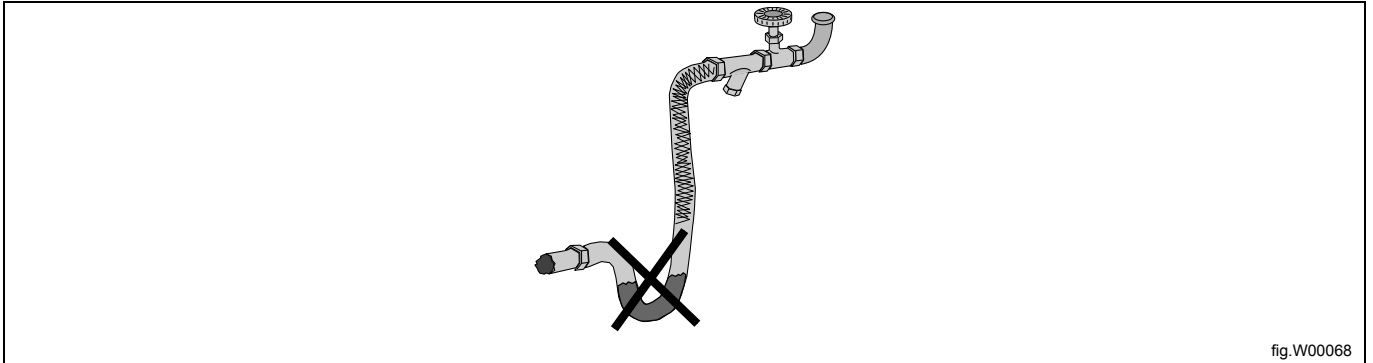

- The branch pipe's branch must be located at the top of the main steam pipe to prevent condensation in the steam.
- The branch pipe must have a descending gradient and must end at a height above the inlet connecting branch (D).
- Mount a shut-off valve (a) and a strainer (b) in the branch pipe.

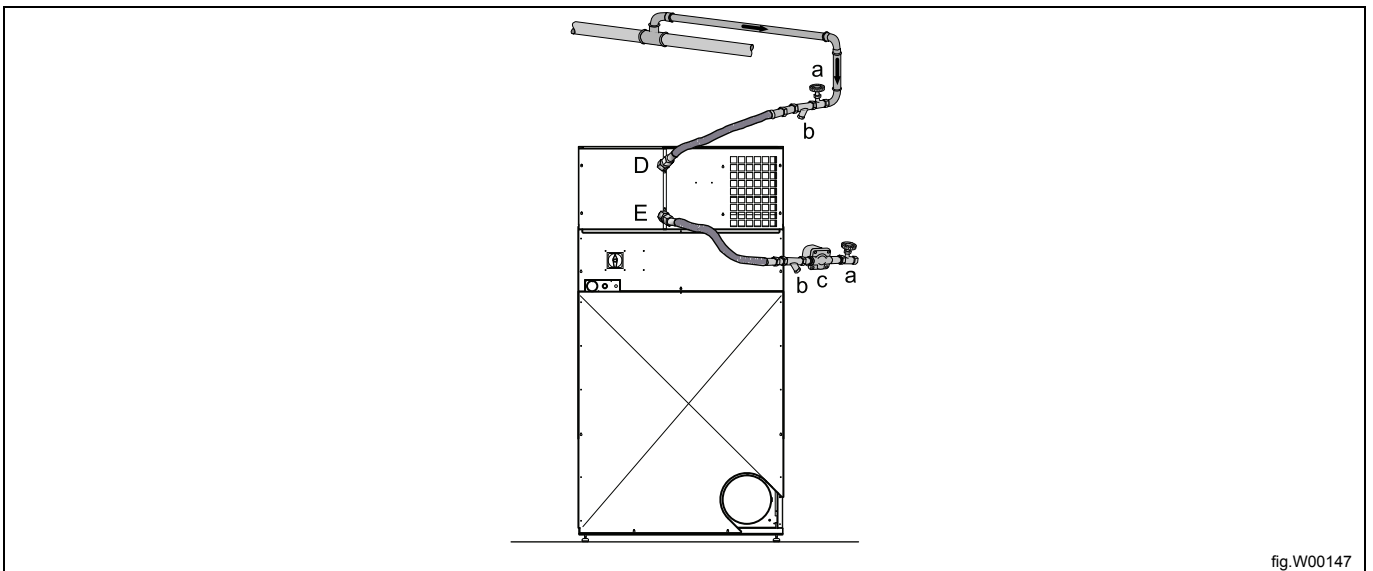

Condensate return

- It is important that the branch pipe for condensed water on return to the main condensate pipe has a descending gradient and is lower than the outlet connecting branch (E).
- Mount a strainer (b) in the return pipe.
- Mount a steam trap behind the dirt collector (c).
- Then mount a shut-off valve (a).
- Mount pressure hoses between branch pipes and machine (hoses are not supplied).
- The pressure hoses must not hang down.

Leak test

Leak test the system.

Clean the dirt collectors (b).

Pipe insulation

All pipes must be insulated in order to reduce risk of burning. Insulation also reduces loss of heat to the surroundings.

6 Gas connection

6.1 General



Caution



It is your responsibility to have all plumbing connections made by a qualified professional to insure that the gas plumbing installation is adequate and conforms with local and state regulations or codes. In the absence of such codes, ALL plumbing connections, material, and workmanship must conform to the applicable requirements of the National Fuel Gas Code ANSI Z223.1 LATEST EDITION or the CAN/CGA—B149, INSTALLATION CODES, both the latest edition.

Mount a shut-off valve upstream from the machine.

The gas connection to the machine should be dimensioned to an output depending upon the kW-rating of the machine.

The factory nozzle pressure setting must correspond to the fuel value given on the data label.

Check that the nozzle pressure and fuel value correspond with the values in the gas tables on the following pages. If not, contact the supplier.

Bleed the pipe system before connecting the machine.

After connection, test all joints for leaks.

The machine and its individual shut-off valve must be disconnected from the gas supply piping system during any pressure testing of the system at test pressures in excess of 1/2 psi (3.5 kPa).

The machine must be isolated from the gas supply piping system by closing its individual manual shut-off valve during any pressure testing of the gas supply piping system at test pressures equal to or greater than 1/2 psi (3.5 kPa).

A minimum 1/8 inch N.P.T plugged tap, accessible for test gage connection, must be installed immediately upstream from the gas supply connections to the machine.

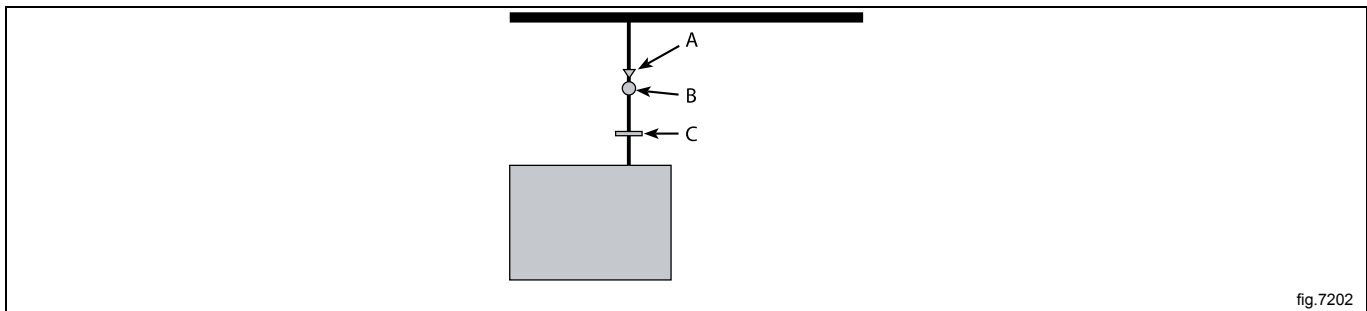

fig.7202

A = Pressure regulator (option) propane only

B = Gas shut-off valve

C = 1/8 inch N.P.T plugged tap

6.2 Gas installation

This machine has been built to run on natural gas. If the machine is to be converted to another type of gas, the gas nozzle must be replaced.

Conversion kit for propane gas is enclosed in secondary packing. Please contact your dealer if the current gas type is not propane/natural gas.

6.3 Table of pressure and adjustment

D7100

Gas category	Heating power (BTH/h)	Inlet pressure (WC")	Injector pressure (WC")	Injector size (ø mm)	Air reducing plate (mm)	Label number
Natural	218600	7	3.2	5.00	487153397 ø 32 mm	Default
Propane	218600	11	11	3.00	487153397 ø 32 mm	490375771

D7135

Gas category	Heating power (BTH/h)	Inlet pressure (WC")	Injector pressure (WC")	Injector size (ø mm)	Air reducing plate (mm)	Label number
Natural	280000	7	3.2	5.65	487153396 ø 40 mm	Default
Propane	280000	11	11	3.40	487153398 ø 36 mm	490375781

6.4 Nozzles sizes depending on altitudes

The nozzles have to be ordered separately from your dealer.

D7100

Altitude (ft.)	Nozzle for natural gas		Nozzle for natural gas	
	Diameter mm	Art. No	Diameter mm	Art. No
0–1999	5	471985354*	3.1	471985357*
2000–3999	4.7	471985376	2.9	471985391
4000–5999	4.7	471985376	2.9	471985391
6000–8000	4.6	471985353	2.6	471985370

D7135

Altitude (ft.)	Nozzle for natural gas		Nozzle for natural gas	
	Diameter mm	Art. No	Diameter mm	Art. No
0–1999	5.65	471985349*	3.6	471985388*
2000–3999	5.5	471985364	3.5	471985348
4000–5999	5.35	471985372	3.3	471985368
6000–8000	5.2	471985390	3.3	471985368

* Are enclosed at delivery.

6.5 Test run

- Loosen the measuring branch screw (2) 1/4 turn; connect a manometer to the measuring branch.
- Select a program with heat.
- Start the machine.
- Check the nozzle pressure, see “Table of pressure and adjustment”.
- If necessary adjust the regulator setting screw (4) behind the cover screw (3). Replace the cover screw (3) if removed.
- Check that the gas is burning evenly.

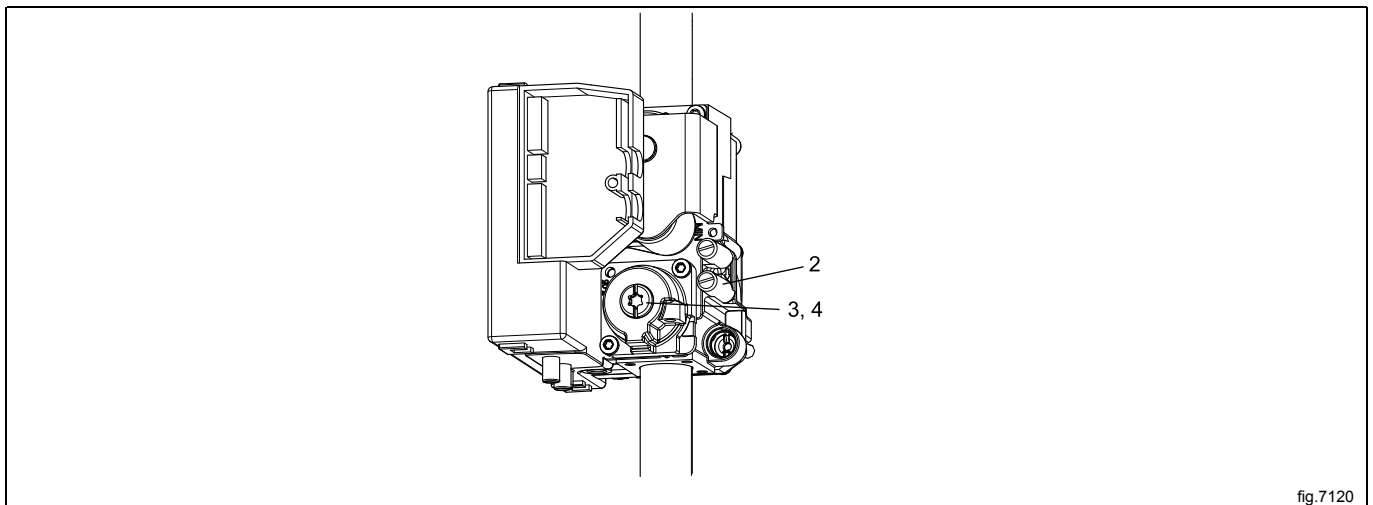

fig.7120

6.6 Converting instructions

- Disconnect the power to the machine.
- Demount the back panel.
- Remove the nozzle (1).
- Mount the new supplied nozzle.

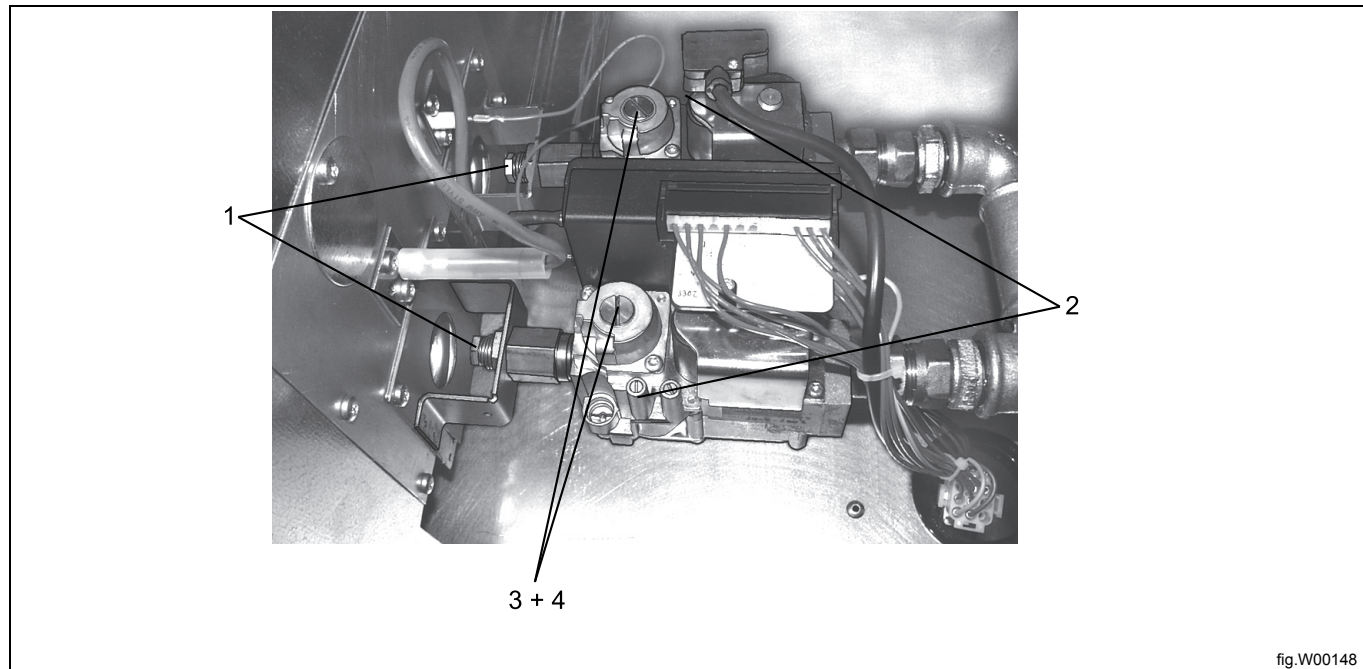

fig.W00148

- Loosen the measuring branch screw (2) 1/4 turn; connect a manometer to the measuring branch.
- Connect the power to the machine and select a program with heat.
- Start the machine.
- Set the correct nozzle pressure according to the "Pressure and adjustment table" on setting screw (4) under the cover screw (3).

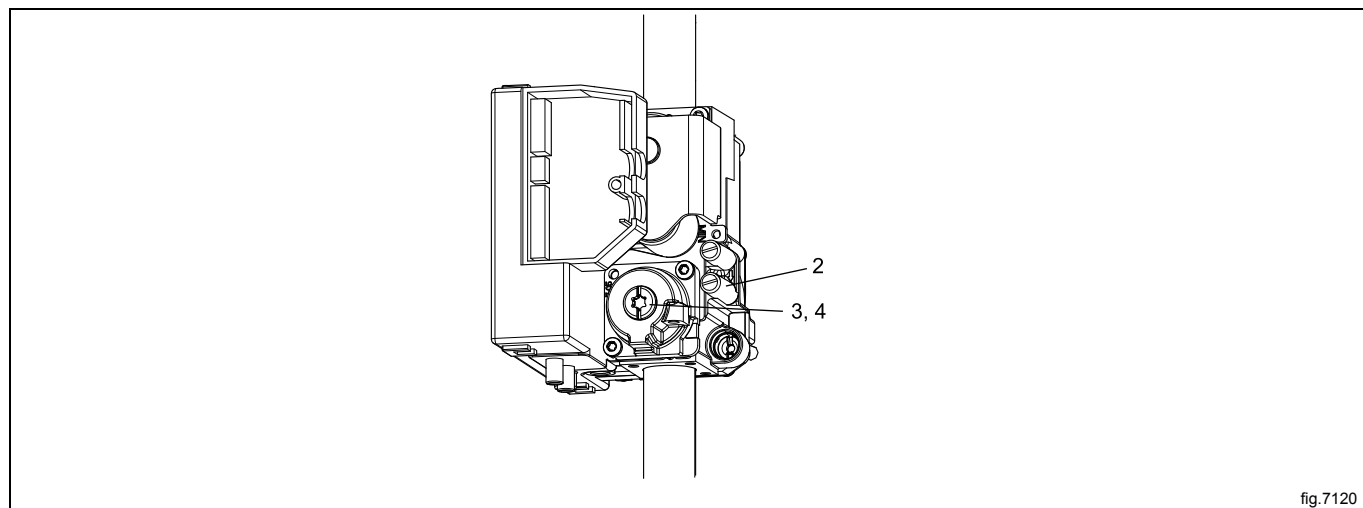

fig.7120

- Check that the gas flame burns evenly.
- Mount the cover screw (3).
- Remount the back panel.

6.7 Converting from natural gas to propane gas

This machine has been build to run on neutral gas. If the machine is to be converted to another type of gas, the gas nozzle must be replaced.

Conversion kit for propane gas is enclosed in secondary packing. Please contact your dealer if the current gas type is not propane/ natural gas.

Disconnect the power to the machine.

Demount the upper rear panel.

Disconnect the cables from the plastic cover and connect to the pressure switch.

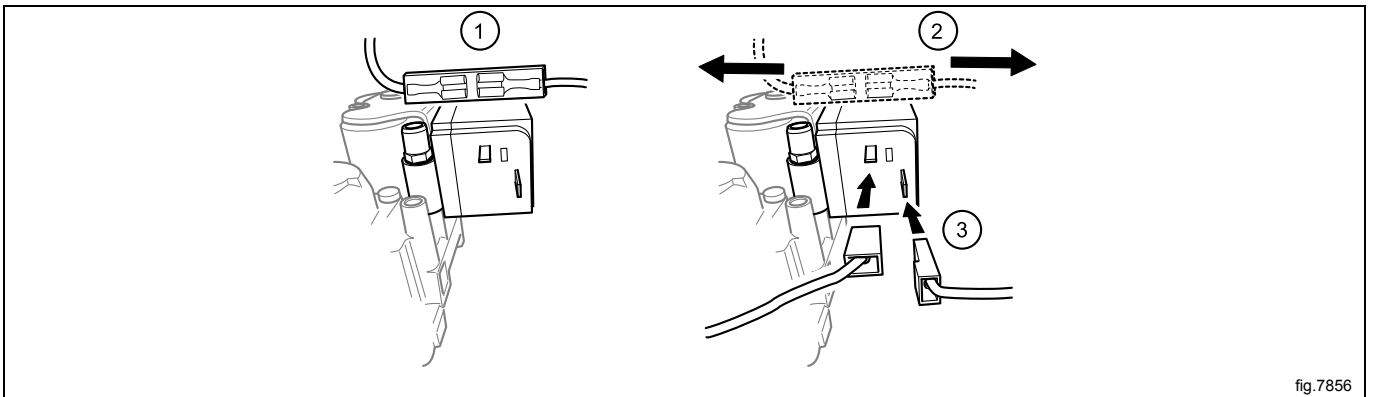

fig.7856

6.8 Data label

When the machine is to be converted to another gas type, the data label at the rear of the machine must be updated in order for the data to be correct.

Place the data label enclosed in the conversion kit on top of the data label as shown below. If there are more than one data label, select the label with the correct country code and gas type.

<p>WXXXXX Product no.: 9868XXXXXX Serial no.: 09XXX / 99XXXXX OC: 09XXXXXX Date: 10XX Wiring diag: 432XXXXXXX Program: 432XXXXXX, 5XXX Type: WN3...WN3XXXX ELECTROLUX LAUNDRY SYSTEMS SWEDEN AB</p>	
<p>WXXXXX Product no.: 9868XXXXXX Serial no.: 09XXX / 99XXXXX OC number: 09XXXXXX Date(YMMM): 10XX Capacity: X kg Type/Model: WN3...WN3XXXX Voltage: 380 – 400V 3N ~ 50Hz Rated Input: 1,6kW 10A</p>	
<p>DK,NO,SE,FI,CH,CZ,EE,LT,SI,TR,BG,RO : I2H GB,ES,GR,IE,IT,PT,AT,LV,HU,IS,SK : I2H DE,PL,LU : I2E(LL) PIN No 359BS703 MANIF. PRESSURE : 9 MBAR. INJECTOR: Ø2,58 MM NATURAL GAS: G20 (INLET PRES: 20 MBAR, CAL. VAL. 37400 KJ/M3) IP24D</p>	
<p>For safety reasons use only genuine spare parts.</p> <p style="text-align: right;">Made in Sweden Electrolux Laundry Systems AB 341 80 Ljungby, Sweden.</p>	
<p>WXXXXX Product no.: 9868XXXXXX Serial no.: 09XXX / 99XXXXX OC: 09XXXXXX Date: 10XX Wiring diag: 432XXXXXXX Program: 432XXXXXX, 5XXX Type: WN3...WN3XXXX ELECTROLUX LAUNDRY SYSTEMS SWEDEN AB</p>	

DK,NO,SE,FI,GB,ES,GR,IE,IT,PT,AT: 12H-20 MBAR
DE: 12E(LL)-20MBAR
ID.nr. 359BQ491
MANIF. PRESSURE : 10 MBAR. INJECTOR. Ø3,10 MM
NATURAL GAS: G20-20 MBAR
(INLET PRES: 20 MBAR, CAL. VAL. 37400 KJ/M3)
Art. No.

fig.7110

7 Electrical connection

7.1 Electrical installation



It is your responsibility to have ALL electrical connections (including grounding) made by a properly licensed and competent electrician, to assure that the electric installation is adequate and conforms with local and state regulations or codes. In the absence of such codes, ALL electric connections, material, and workmanship must conform to the applicable requirements of the NATIONAL ELECTRIC CODE ANSI/NFPA NO. 70—or the CANADIAN ELECTRICAL CODE, CSA C22.1 — both the latest edition.

A separate circuit serving each machine must be provided. The machine must be connected to copper wire only. DO NOT use aluminum wire which could cause a fire hazard.

Note!

The machine is equipped with a control circuit transformer set for an incoming supply of 120 volts or 240 volts.

7.2 Internal connection

Demount the rear panel (A) with the supply disconnecter grip.

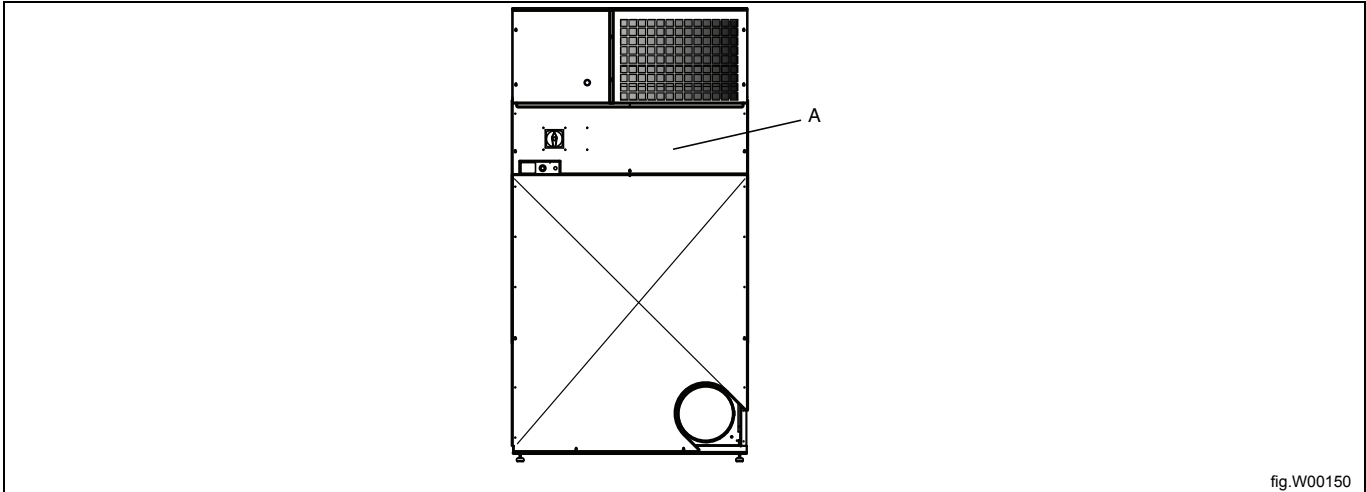

fig.W00150

Lead cable through the cable gland to the supply disconnecter.

Connect the cable as illustrated. If there is a neutral conductor it must be connected to terminal N.

Wiring diagrams for all heating types are enclosed in the drum.

Wiring diagrams for the specific machine are enclosed in a plastic bag at the location showed in the figure (B).

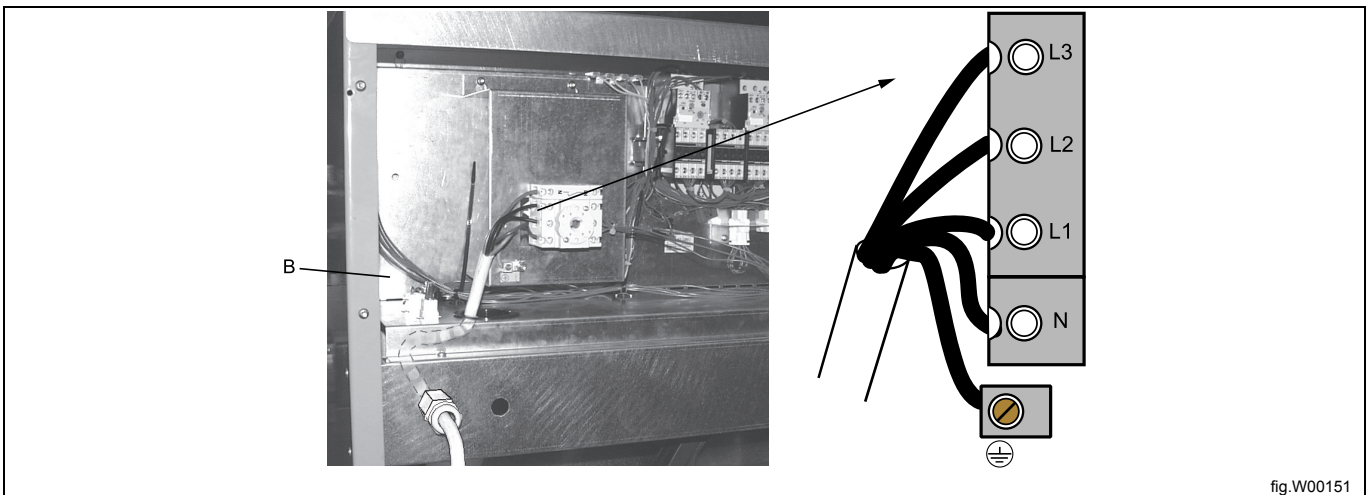

fig.W00151

Note!

The machine must be equipped with supplementary protection in accordance with heavy current regulations.

7.3 Electrical connections

D7100

Heating alternative	Main voltage	Hz	Heating effect kW	Motor effect blower motor / drum motor kW	Max effect kW	Recommended fuse ITCB A
Electric heated	230/240 V 3 ~	50/60	48	1.1 / 1.5	51	160
	400/415V 3 ~	50	48	1.1 / 1.5	51	80
	400/415/440/480V 3 ~	60	48	1.1 / 1.5	51	80
	400/415V 3 ~	50	60	1.1 / 1.5	63	100
	400/415/440/480V 3 ~	60	60	1.1 / 1.5	63	100
Gas heated	200/230/240V 3 ~	50/60	64	1.1 / 1.5	3.3	20
	400/415V 3 ~	50	64	1.1 / 1.5	3.3	16
	400/415/440/480V 3 ~	60	64	1.1 / 1.5	3.3	16
Steam heated	200/230/240V 3 ~	50/60	-	1.1 / 1.5	3.3	20
	400/415V 3 ~	50	-	1.1 / 1.5	3.3	16
	400/415/440/480V 3 ~	60	-	1.1 / 1.5	3.3	16

D7135

Heating alternative	Main voltage	Hz	Heating effect kW	Motor effect blower motor / drum motor kW	Max effect kW	Recommended fuse A
Electric heated	400/415V 3 ~	50	60	1.1 / 1.5	63	100
	400/415/440/480V 3 ~	60	60	1.1 / 1.5	63	100
	400/415V 3 ~	50	72	1.1 / 1.5	75	125
	400/415/440/480V 3 ~	60	72	1.1 / 1.5	75	125
Gas heated	200/230/240V 3 ~	50/60	82	1.1 / 1.5	3.3	20
	400/415V 3 ~	50	82	1.1 / 1.5	3.3	16
	400/415/440/480V 3 ~	60	82	1.1 / 1.5	3.3	16
Steam heated	200/230/240V 3 ~	50/60	-	1.1 / 1.5	3.3	20
	400/415V 3 ~	50	-	1.1 / 1.5	3.3	16
	400/415/440/480V 3 ~	60	-	1.1 / 1.5	3.3	16

8 Installation of heating unit

8.1 Gas heating unit installation

Note!

The procedure when mounting the heating unit is the same on machines with standard door and with sliding door. The following pictures shows a standard door except from pages relating specifically to sliding door.

Heating unit

The heating unit is to be mounted on top of the machine.

It is recommended that the mounting is carried out by two persons.

Use the supplied screws.

Unpacking

Unpack the heating unit.

Note!

During transport the side panels and brace are placed in the back of the tumble dryer (A).

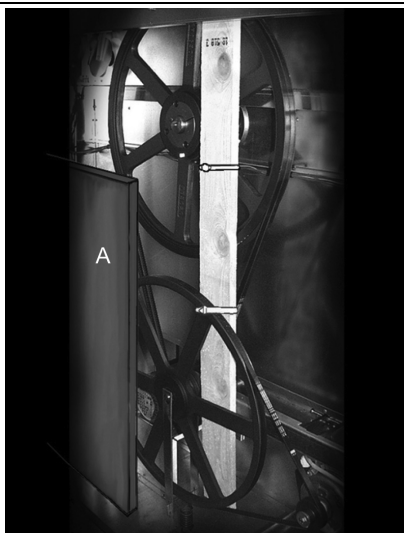

fig.W00142A

Mounting the heating unit

Remove the top panel for the heating unit from the top of the machine where it is placed during transport.



fig.W01153

Demount the two top back panels on the machine.

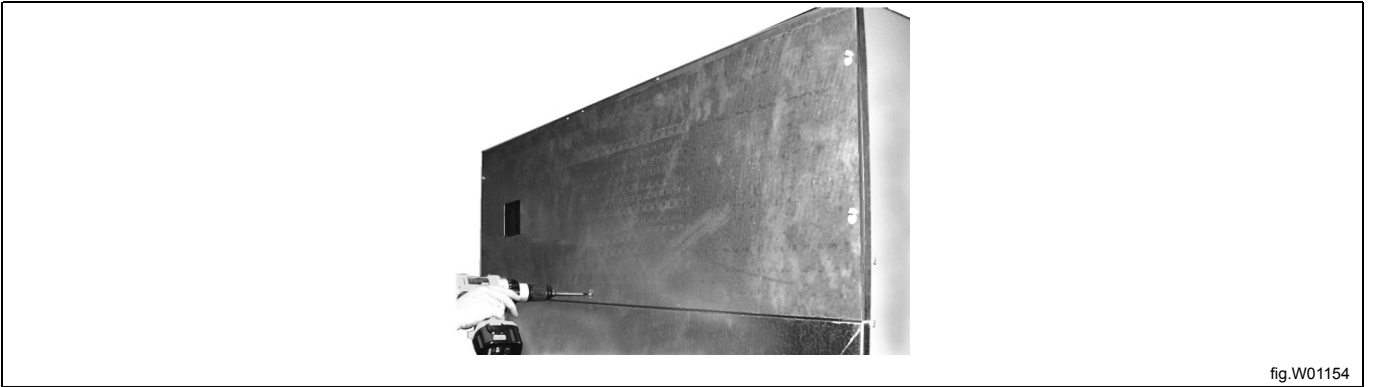

fig.W01154

Lift the gas box and place it on top of the machine.



fig.W01155

Fasten the gas box using 7 screws.

If the machine has sliding door, go to section “Mounting equipment for sliding door”, before carrying out the next step.

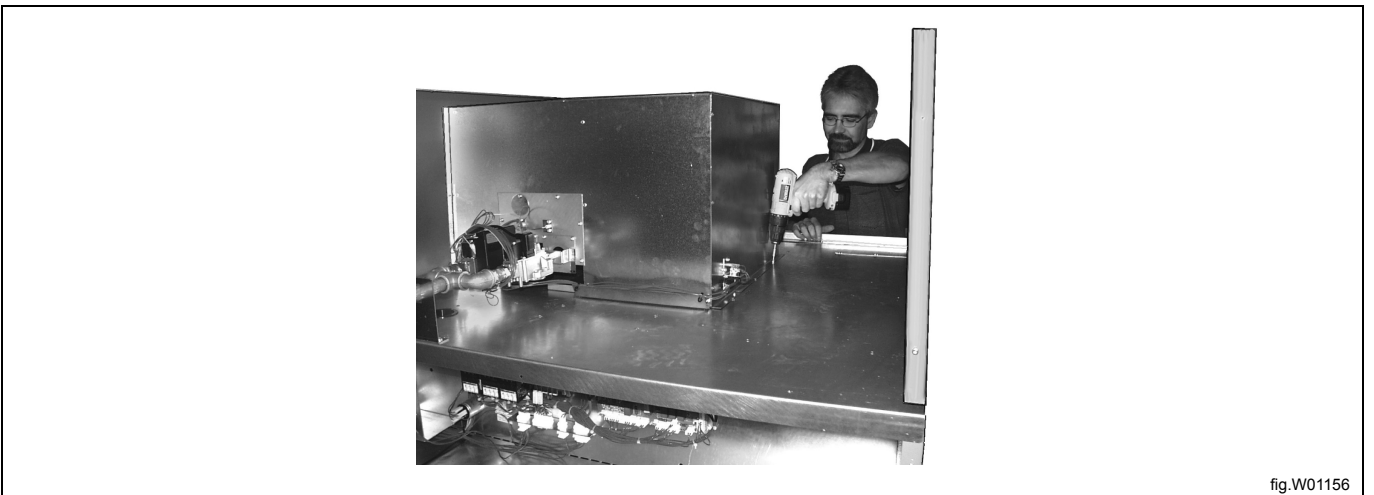
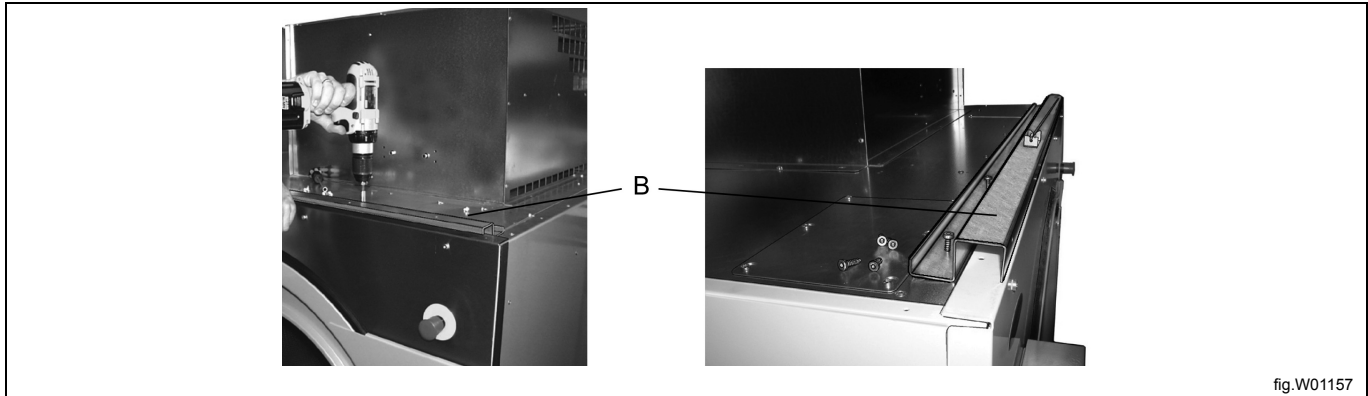

fig.W01156

Fasten the brace (B) using 6 screws.



Fasten the side panels to the bottom using 5 screws on each side as follows:

First fasten the front screw and the back screw but not all the way down. Turn the side panel with the grooves facing downward and mount the side panel in the grooves. Tighten the screws.

Fasten the last 3 screws.

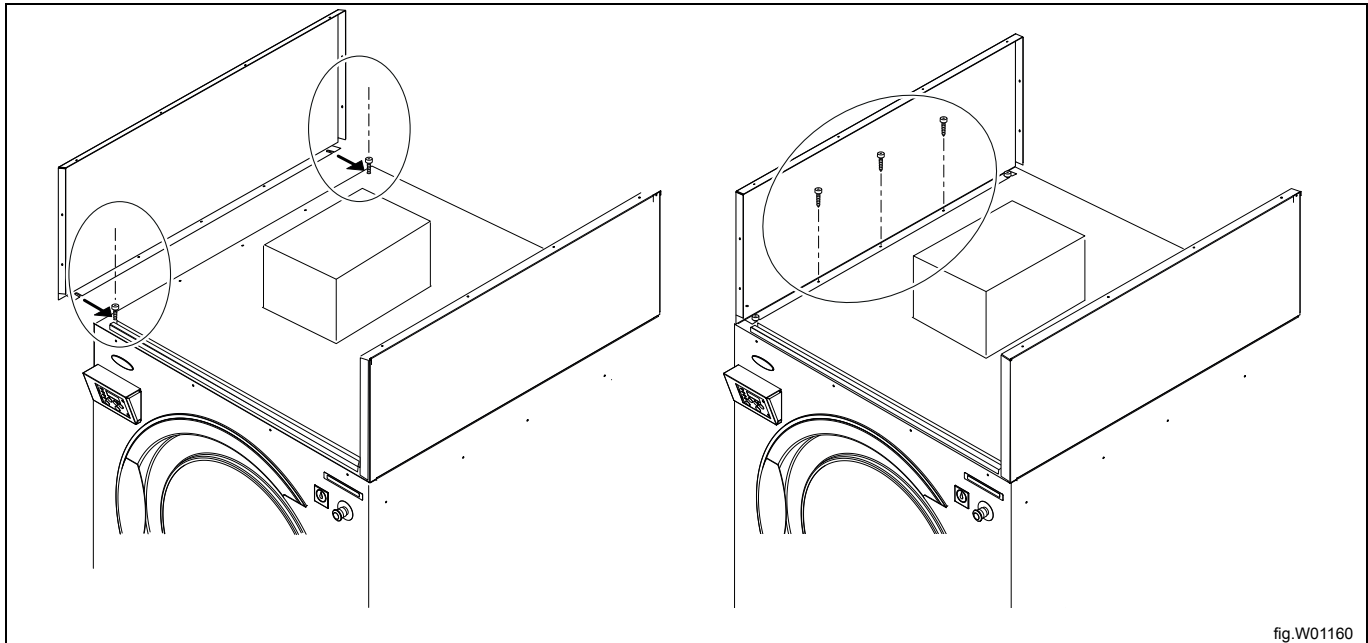

Position the air maze.



Position the top panel.

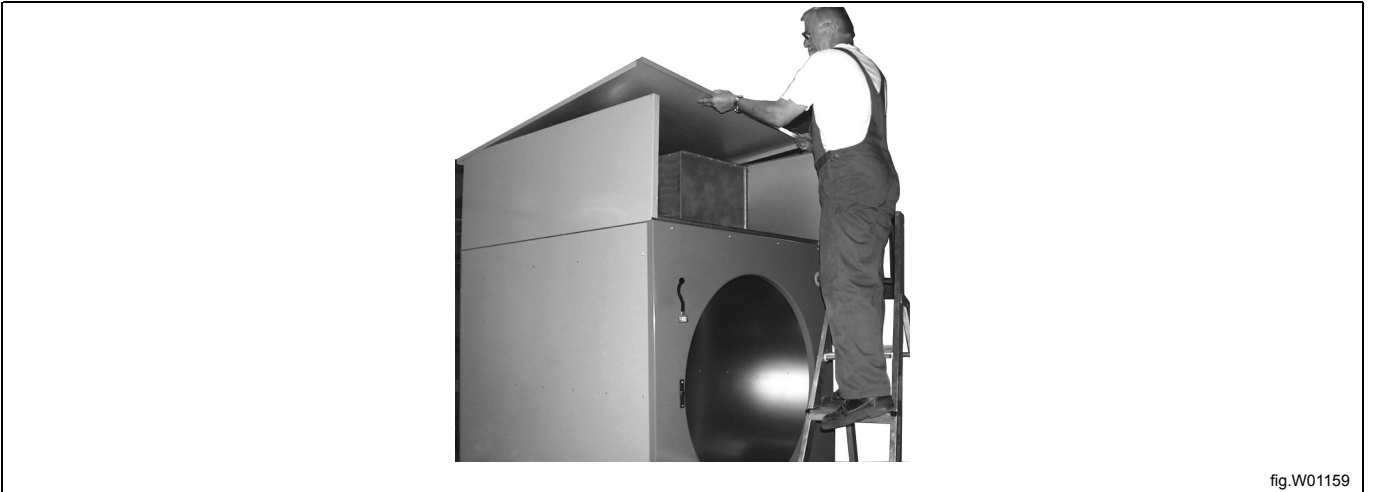

fig.W01159

Fasten the maze using 2 screws.

Fasten the top panel using 4 screws on each side.

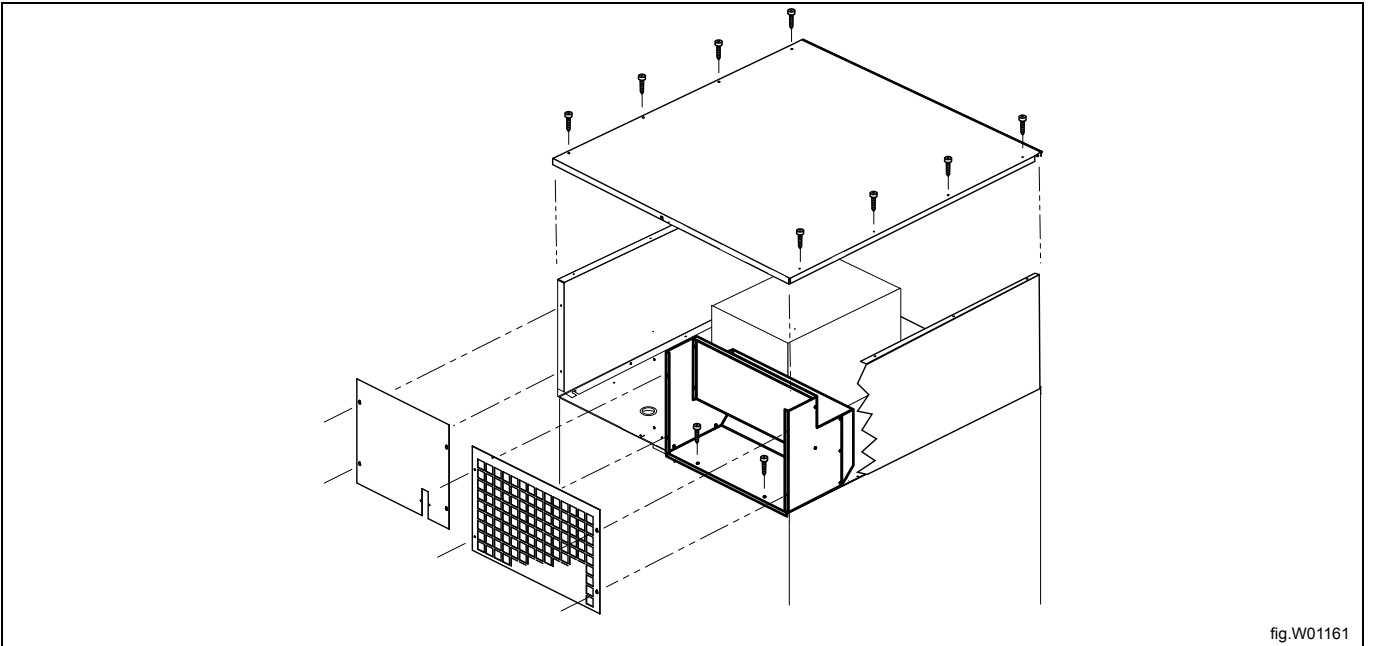

fig.W01161

Mount the front shutter using 2 screws and locking nuts.

Mount the support plate (C).

Lock the front shutter on the front using 2 screws.

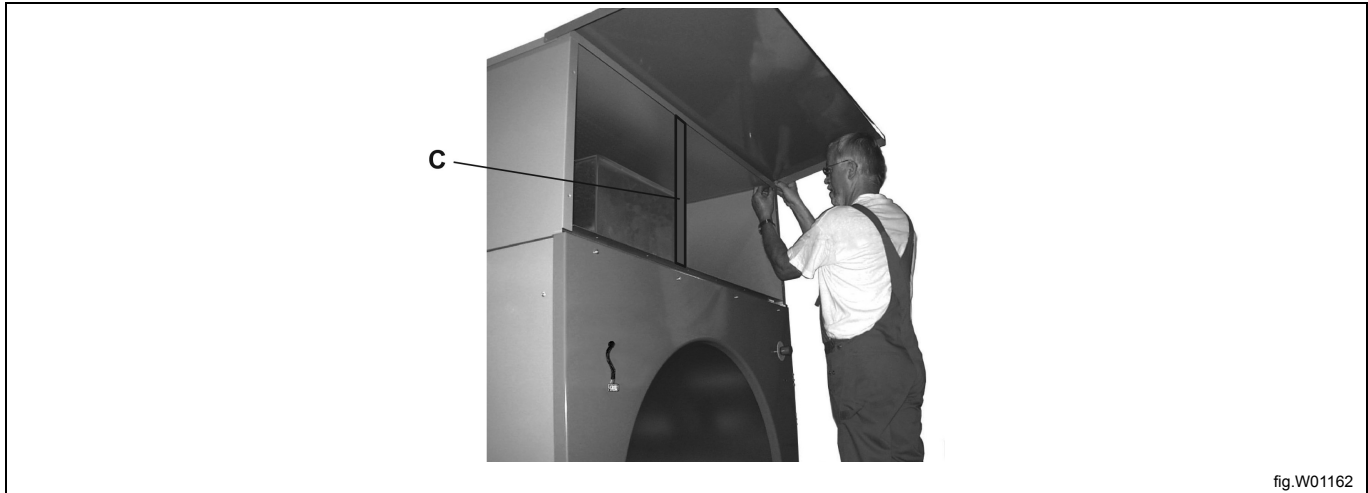

fig.W01162

Mount the supply disconnect, which is mounted on the console, in its place on the component unit using 4 screws.
Place the multiple plug in connector marked *A*.

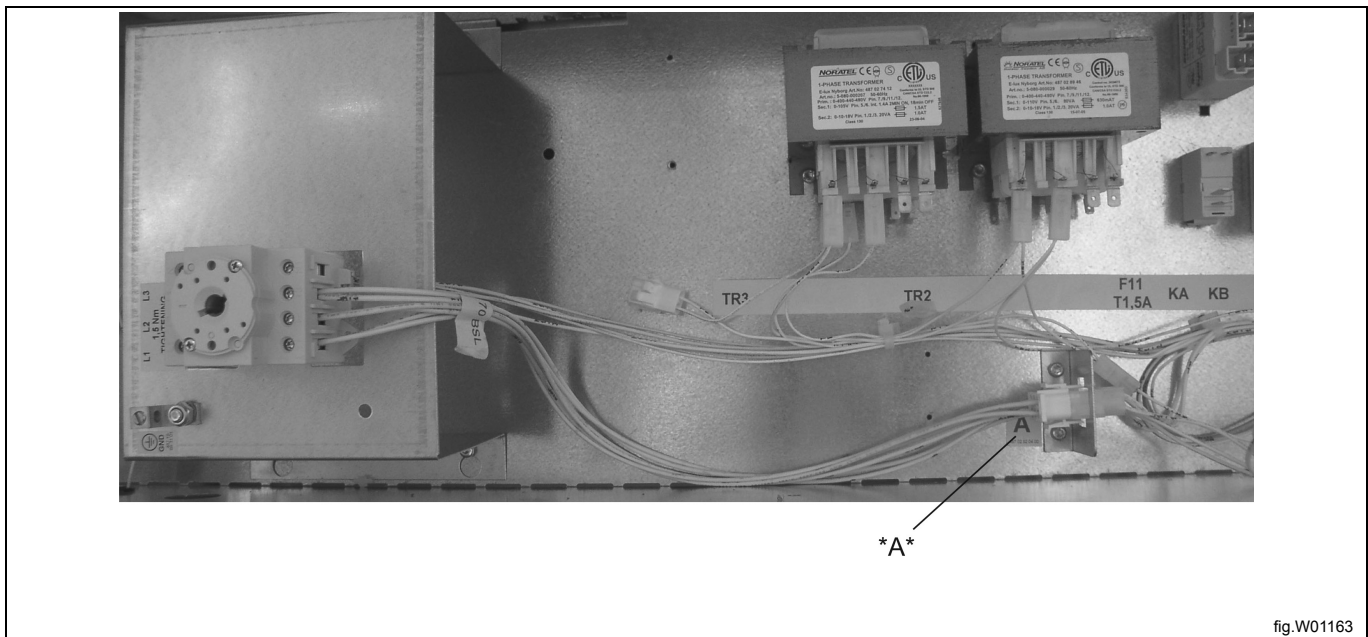

fig.W01163

Lead the multiple plug from the gas control down through the cable gland (D) to the component unit and place it in connector marked *B*. Strap the wires according to the figure.

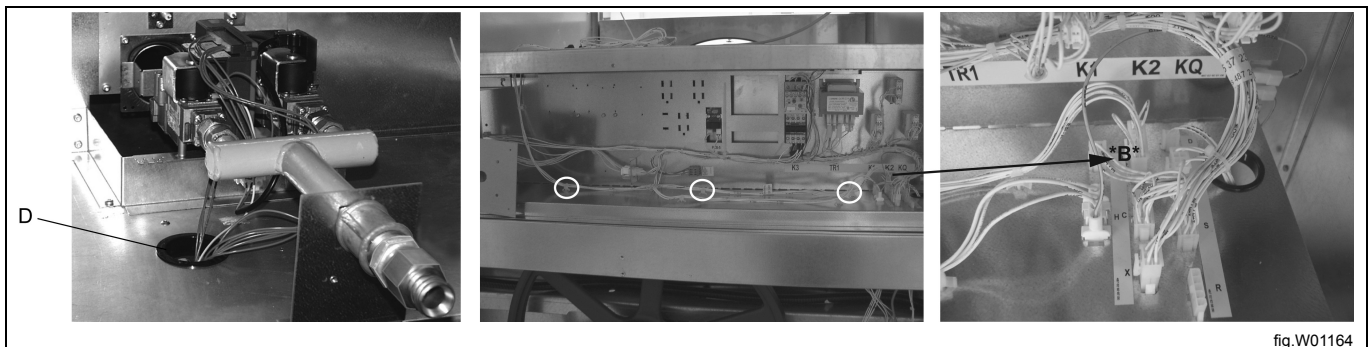

fig.W01164

Place the supply disconnecter panel with handle in its place.
 For more information, see section "Electrical connection".

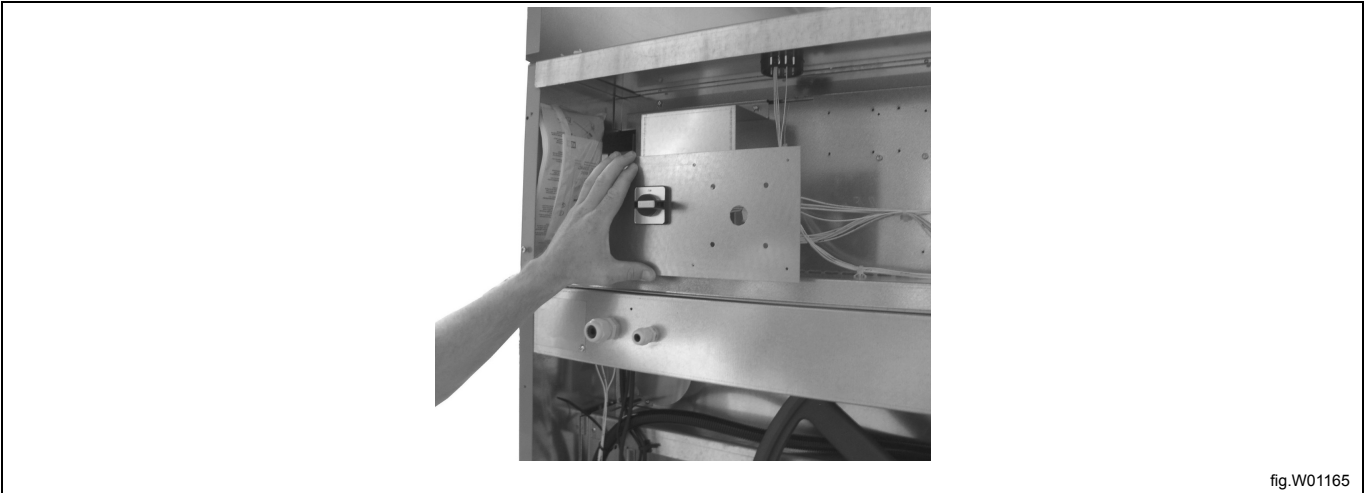

fig.W01165

Mount the back panels (E).
 When mounting the component unit back panel (G) its top edge must be tilted under the basic machine's top panel.
 E: 2 back panels: Heating unit (6 screws)
 F: Top panel: Basic machine
 G. Back panel: Component unit (6 screws)



fig.W01166

Screw the supply disconnecter panel with handle into the back panel using 6 screws.

Note!

Check that the supply disconnecter can connect and disconnect the power.

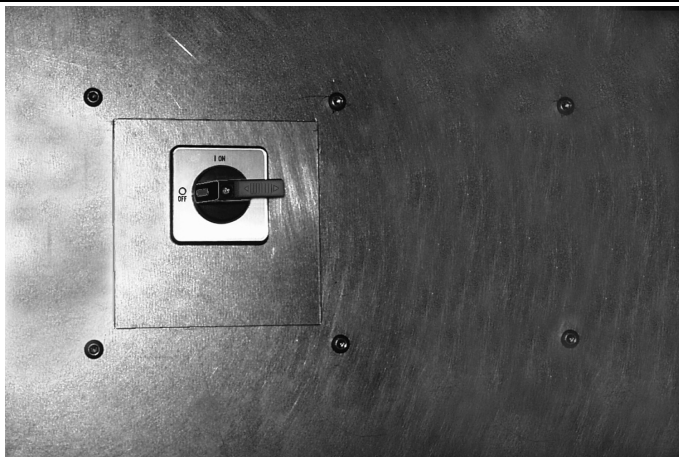

fig.W01167

Connect gas supply.

Mount a manual shut-off valve on the gas pipe upstream from the machine.

For more information, see section "Gas connection".

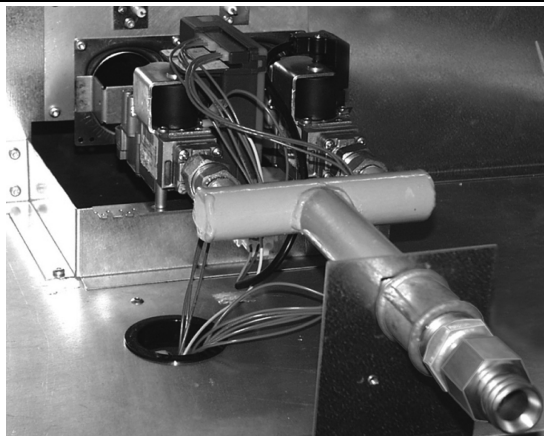

fig.W01168

8.2 Electric heating unit installation

Note!

The procedure when mounting the heating unit is the same on machines with standard door and with sliding door. The following pictures shows a standard door except from pages relating specifically to sliding door.

Heating unit

The heating unit is to be mounted on top of the machine.

It is recommended that the mounting is carried out by two persons.

Use the supplied screws.

Unpacking

Unpack the heating unit.

Note!

During transport the side panels and brace are placed in the back of the machine (A).

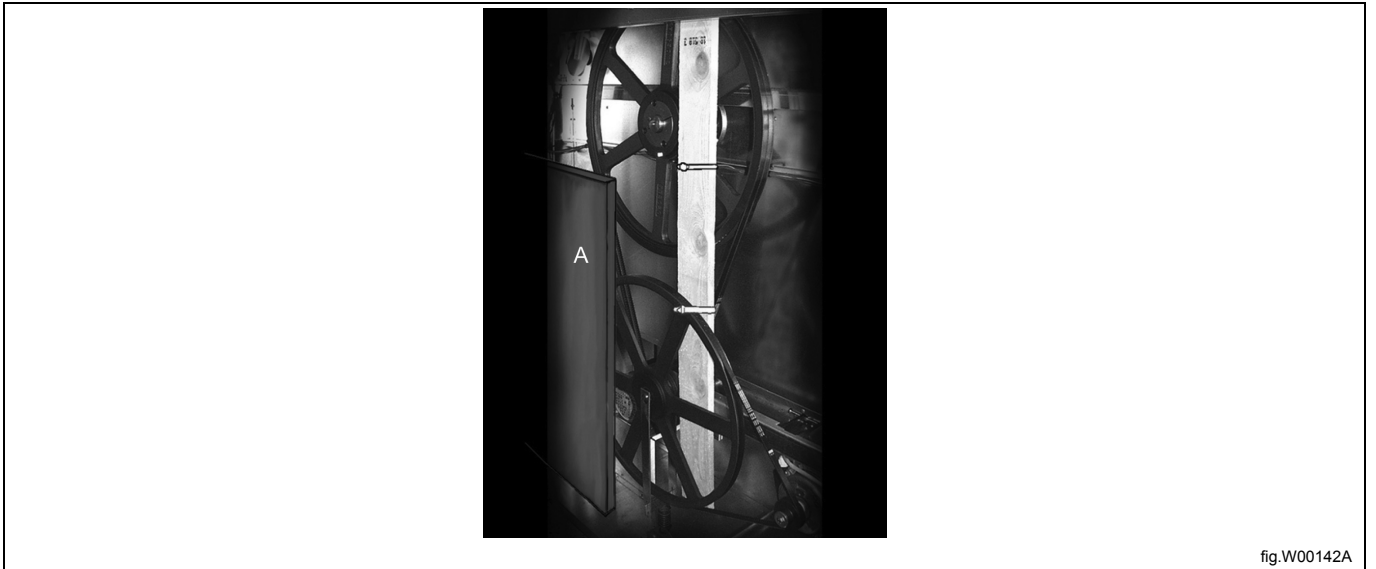

fig.W00142A

Mounting the heating unit

Remove the top panel for the heating unit from the top of the machine where it is placed during transport.



fig.W01153

Demount the two top back panels on the machine.

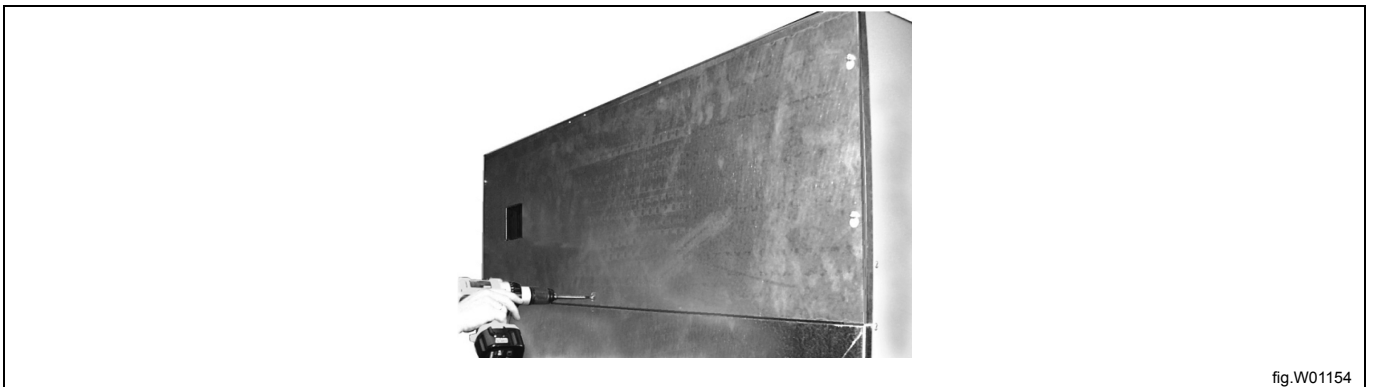
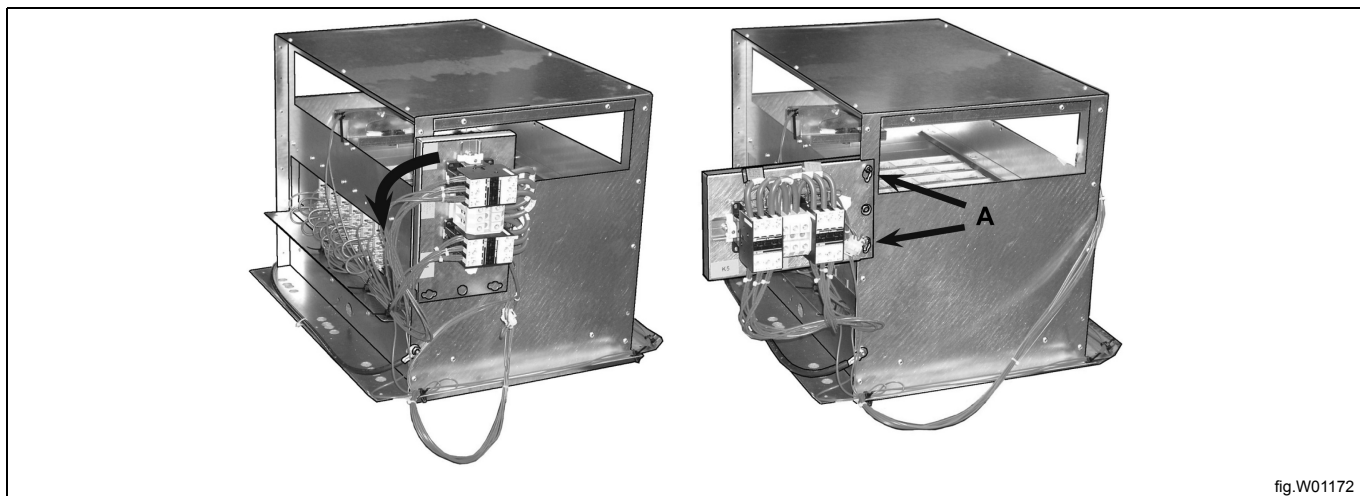

fig.W01154

Check that the electric heating unit is not damaged during transport.

Check that wiring connections and terminals are not bent or defective so there is no risk of short-circuiting.

During transport the contactor console is only fastened loosely, turn it down and fasten it on the side using two screws (A).



Lift the electric heating unit and place it on top of the machine.



Fasten the electric heating unit using 10 screws.

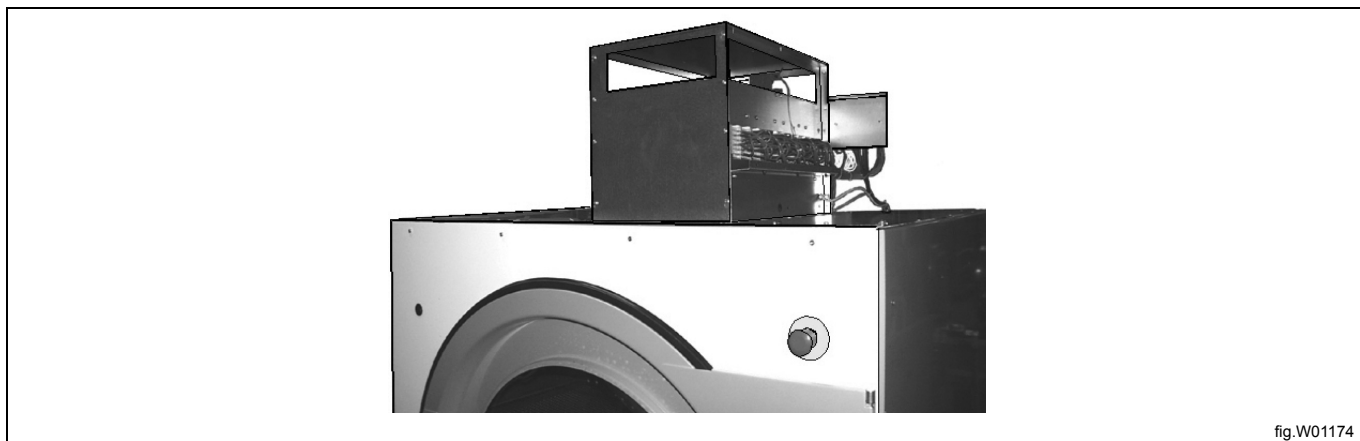

Fasten the brace (B) using 6 screws.

If the machine has sliding door, go to section "Mounting equipment for sliding door", before carrying out the next step.

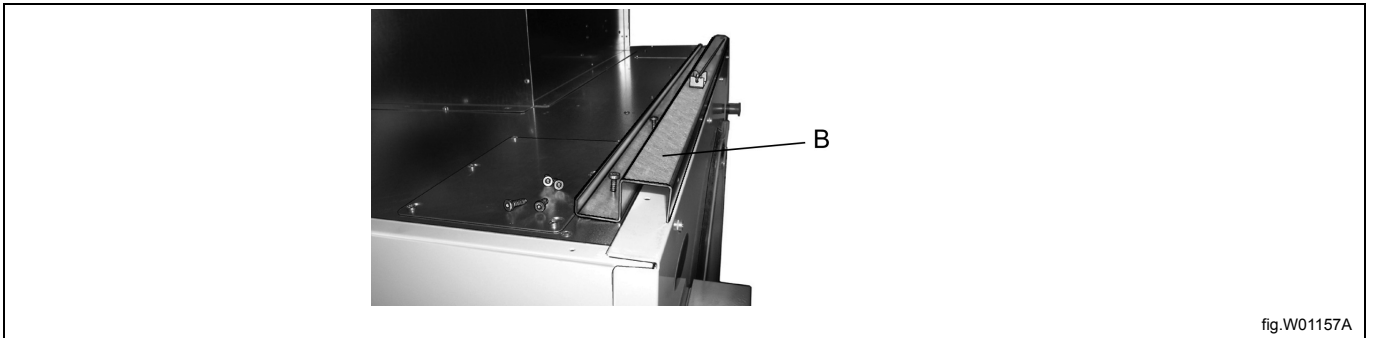

fig.W01157A

Fasten the side panels to the bottom using 5 screws on each side as follows:

First fasten the front screw and the back screw but not all they way down. Turn the side panel with the grooves facing downward and mount the side panel in the grooves. Tighten the screws.

Fasten the last 3 screws.

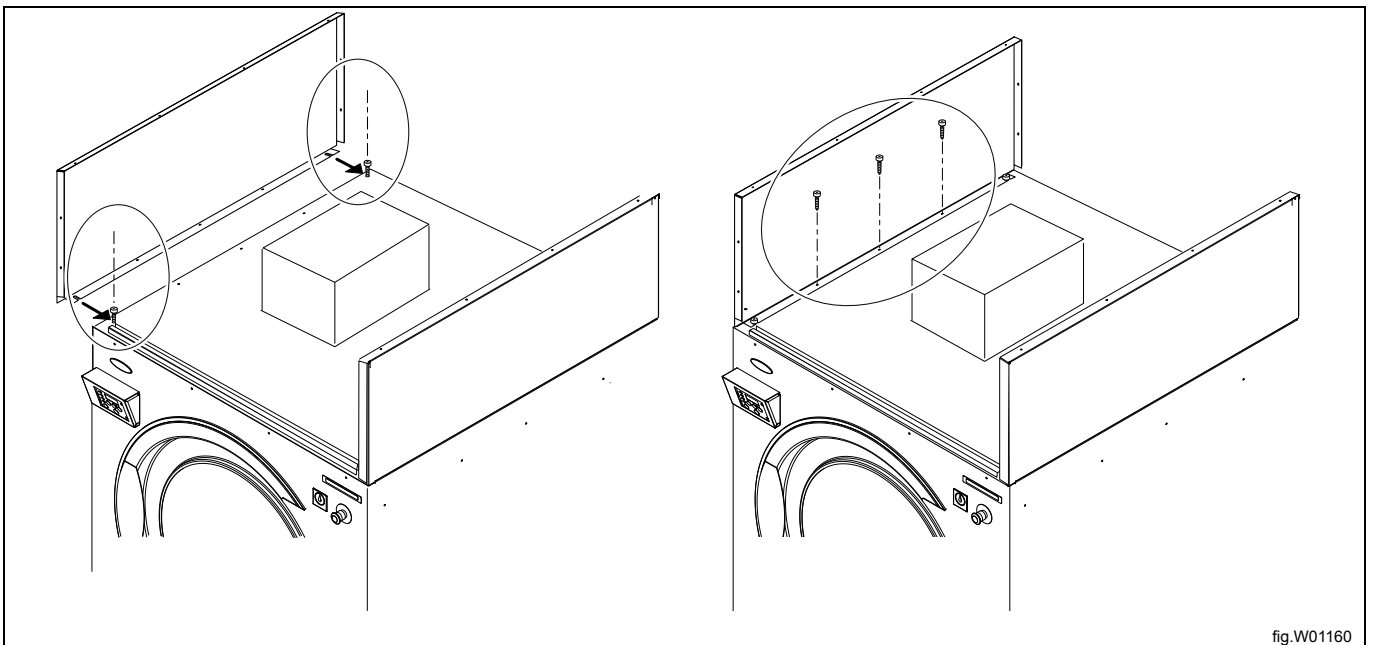

fig.W01160

Position the air maze.

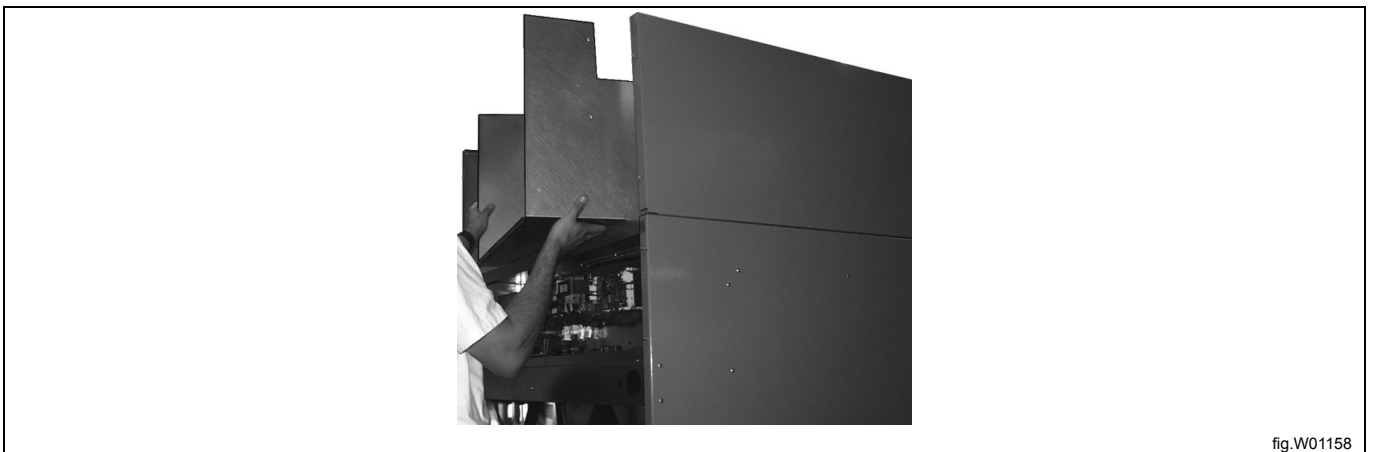

fig.W01158

Position the top panel.

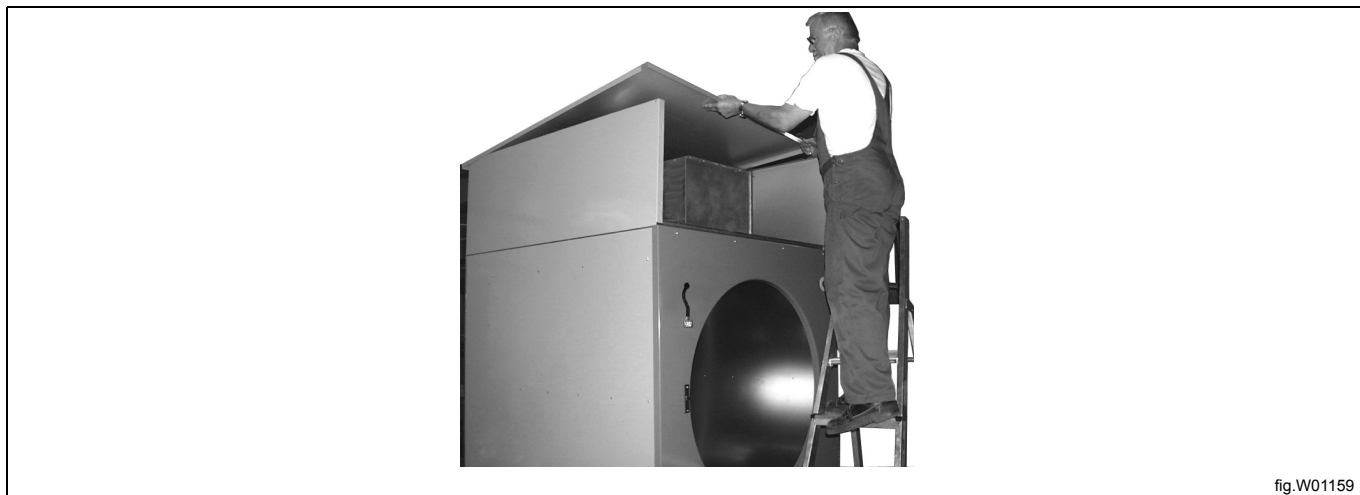

fig.W01159

Fasten the maze using 2 screws.

Fasten the top panel using 4 screws on each side.

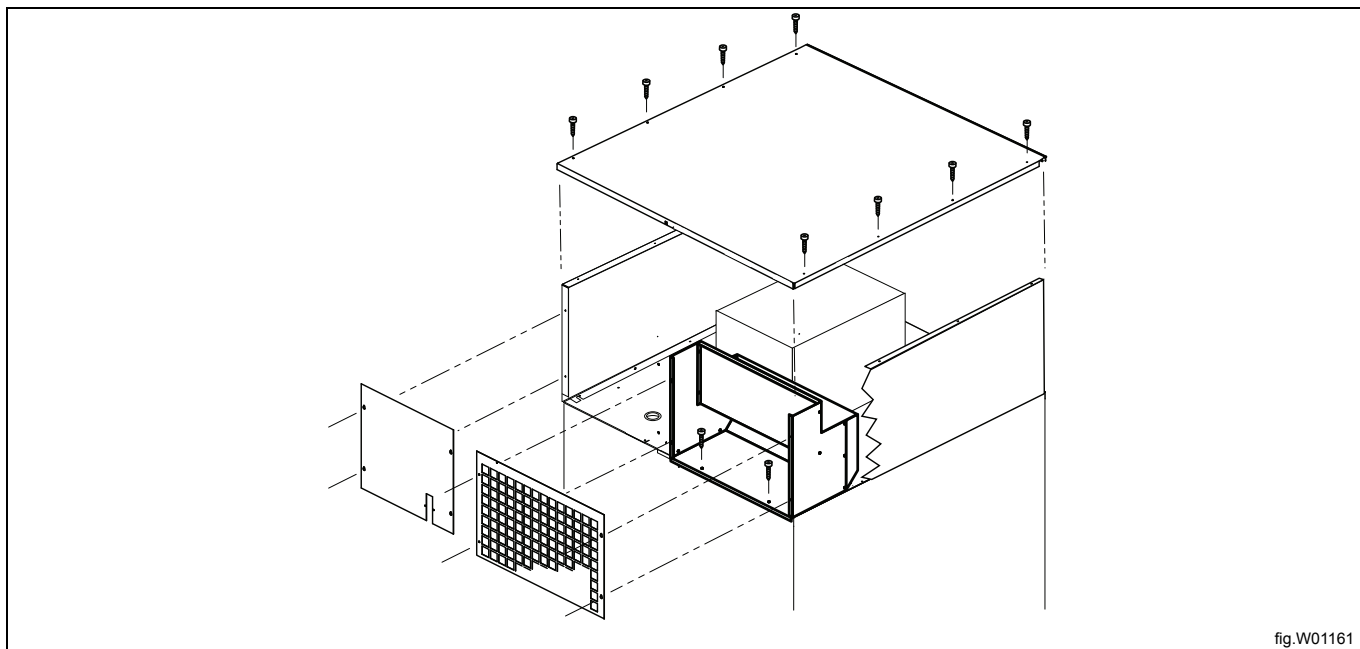

fig.W01161

Mount the front shutter using 2 screws and locking nuts.
 Mount the support plate (C).
 Lock the front shutter on the front using 2 screws.

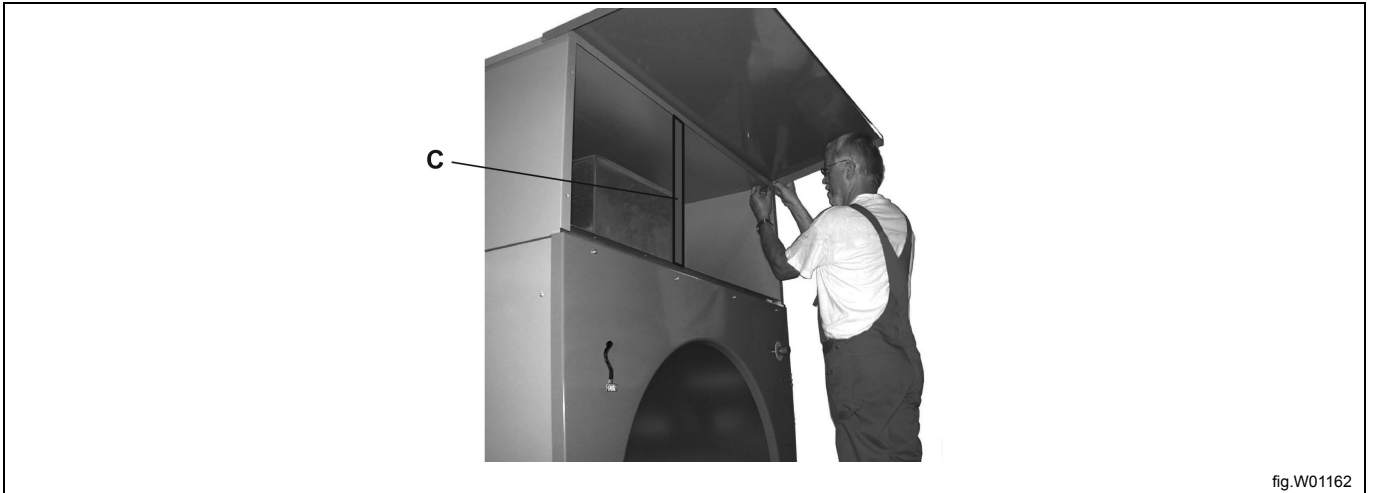

fig.W01162

Mount the supply disconnecter (D), which is mounted on the console, in its place on the component unit using 4 screws. Place the multiple plug in connector marked *A*.

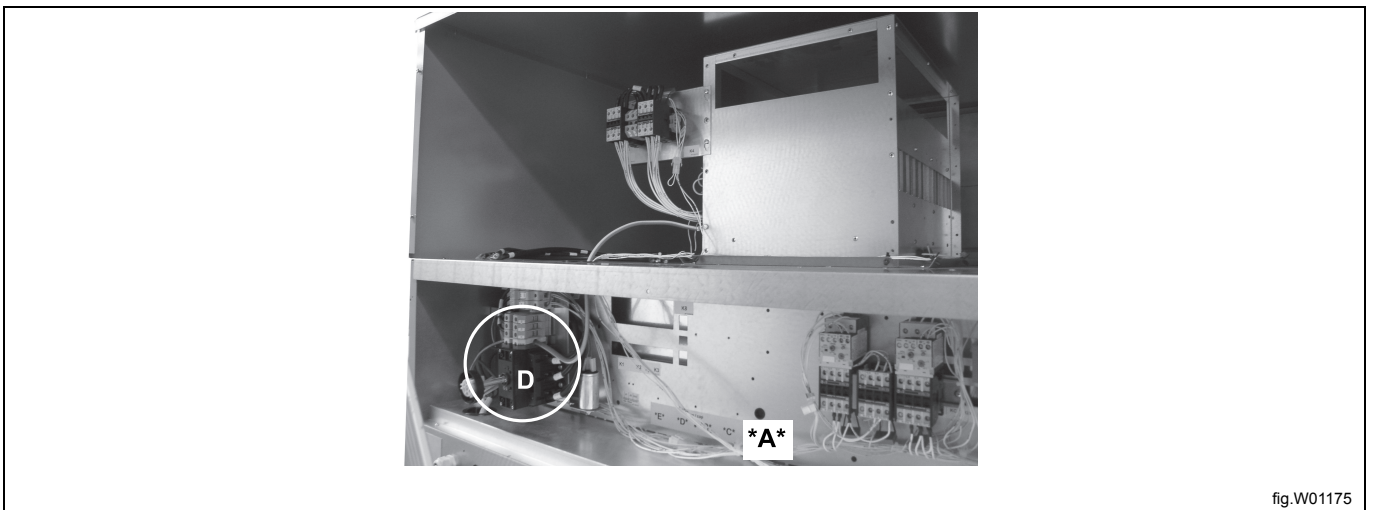

fig.W01175

Lead the multiple plug from the electric heating unit down through the cable gland to the component unit and place it in connector marked *B*. Strap the wires according to the figure.

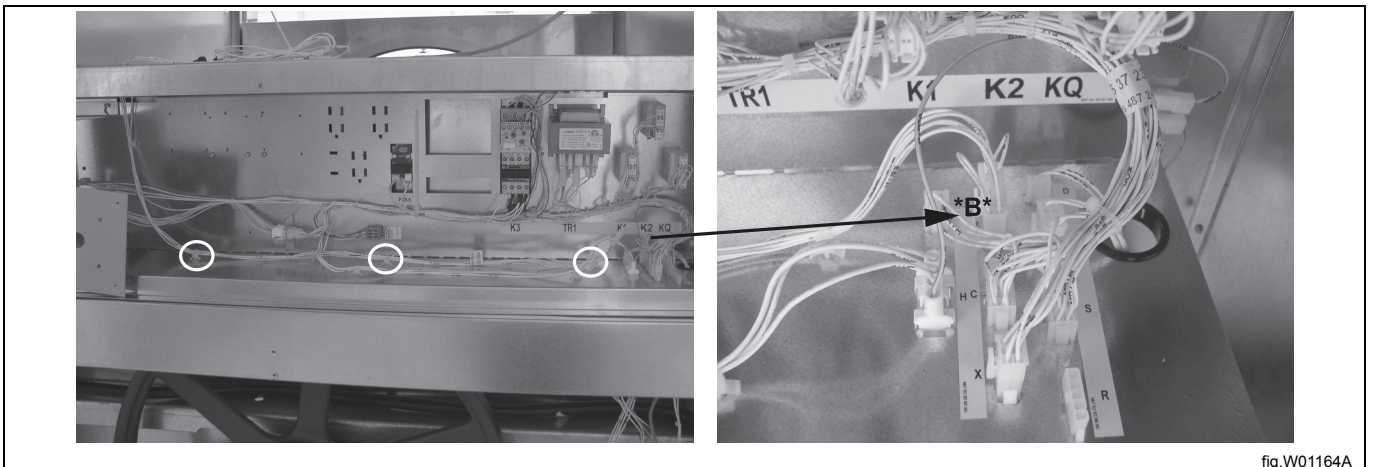

fig.W01164A

Then lead the cables from the supply disconnector through the cable gland to the electric heating unit and place them in L3, L2, L1 on the contactor console (E). Fasten with 2.5 Nm.

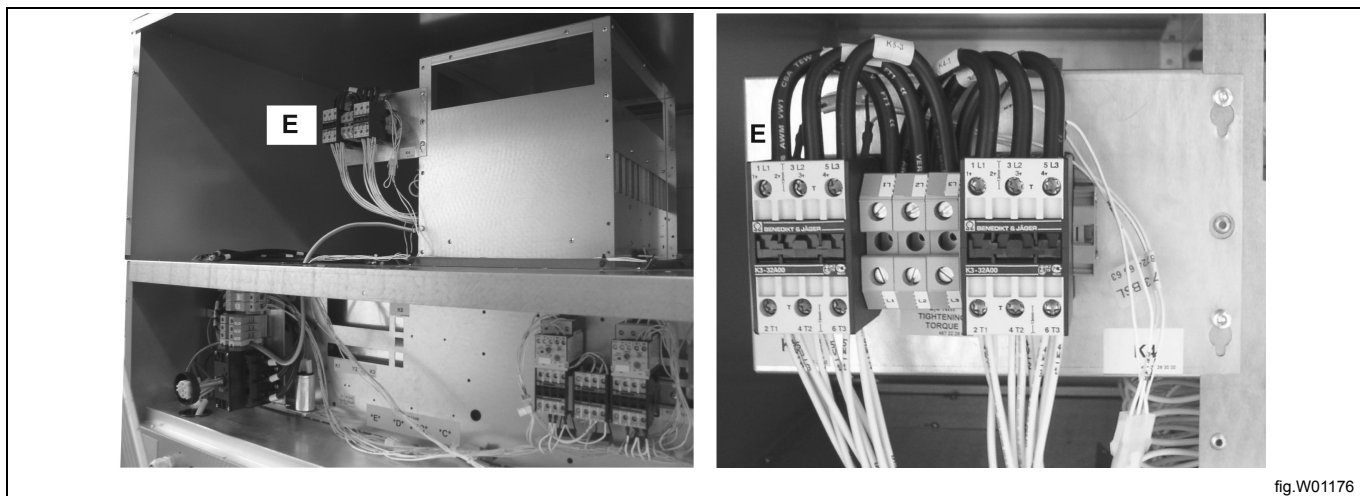

fig.W01176

Lead the earthing conductor from the electric heating unit to GND on the supply disconnector (F). Fasten with 5 Nm. For more information, see section "Electrical connection".

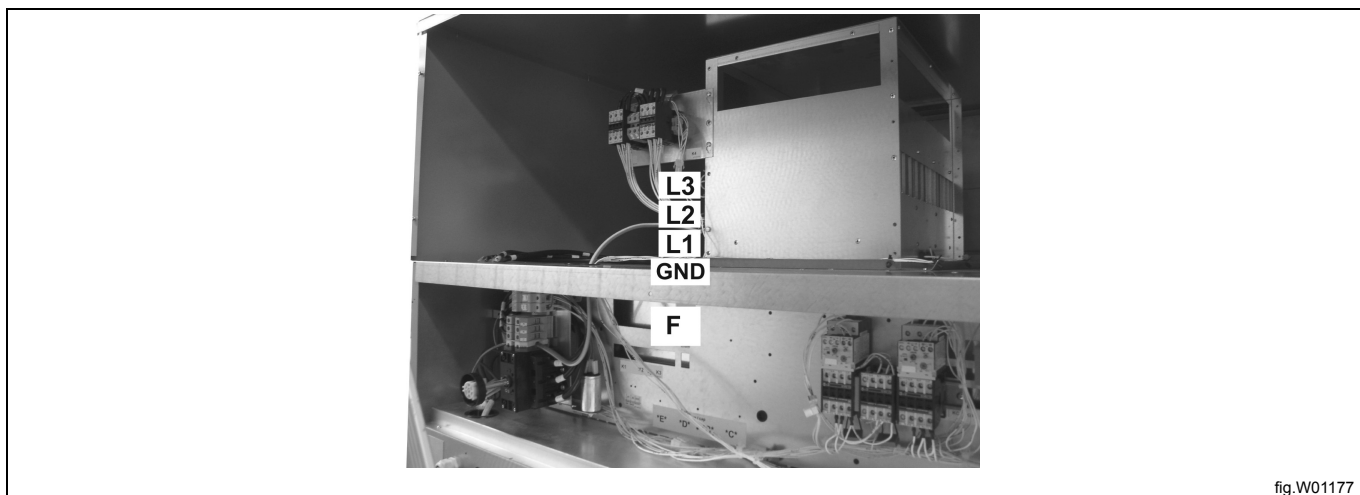

fig.W01177

Place the electrical supply disconnector panel with handle in its place. Mount the supplied M63 cable gland (G) and nut.

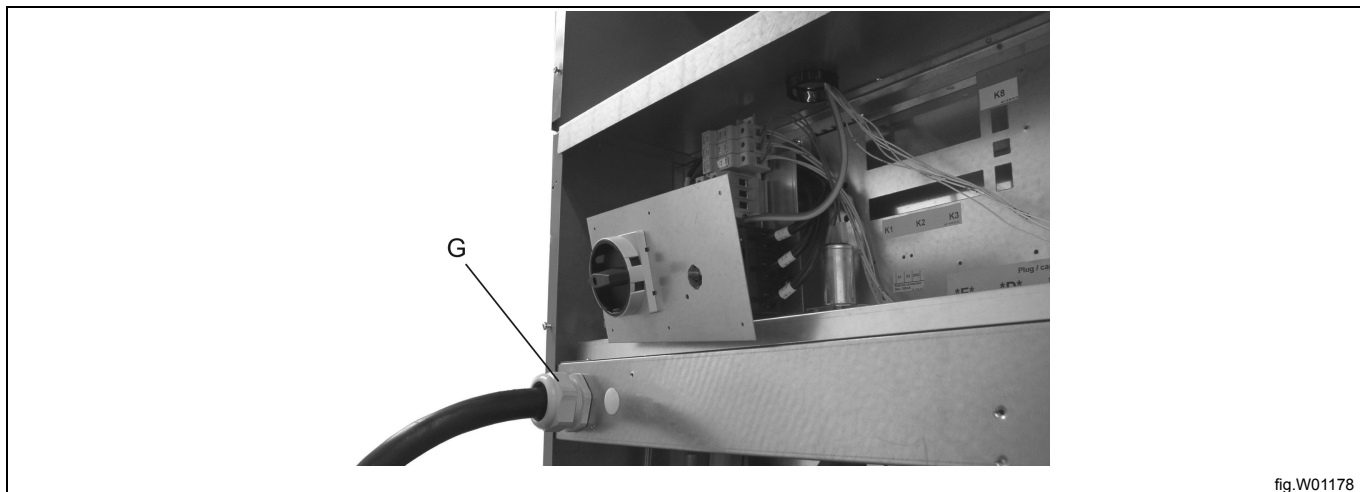

fig.W01178

Mount the back panels (E).

When mounting the component unit back panel (G) its top edge must be tilted under the basic machine's top panel.

E: 2 back panels: Heating unit (7 screws)

F: Top panel: Basic machine

G. Back panel: Component unit (6 screws)



Screw the supply disconnecter into the back panel using 6 screws.

Note!

Check that the supply disconnecter can connect and disconnect the power.

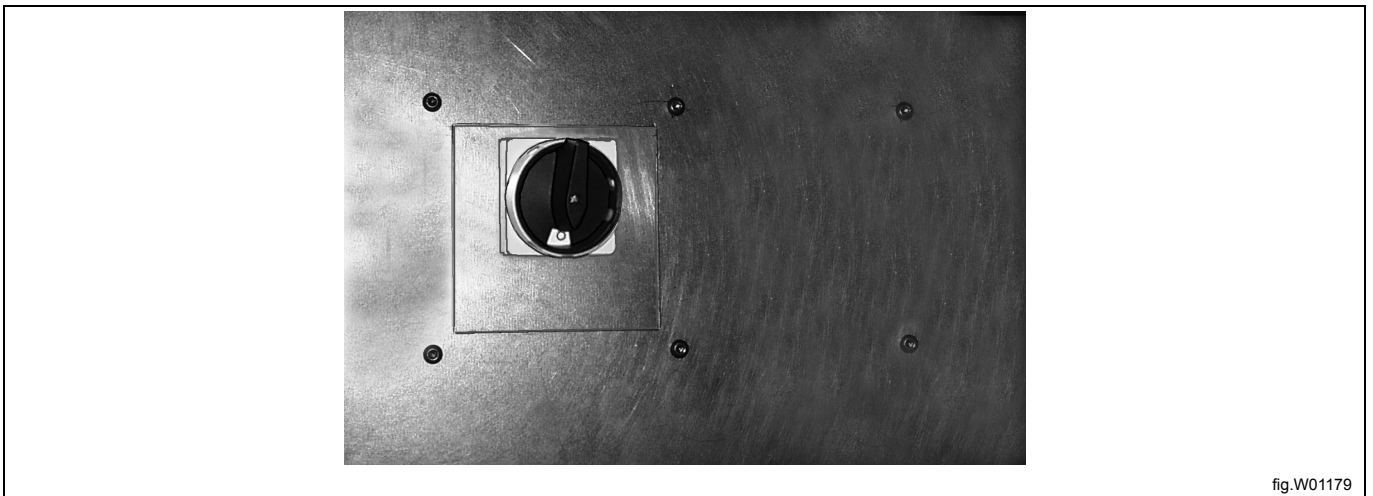

8.3 Steam heating unit installation

Note!

The procedure when mounting the heating unit is the same on machines with standard door and with sliding door. The following pictures shows a standard door except from pages relating specifically to sliding door.

Heating unit

The heating unit is to be mounted on top of the machine.

It is recommended that the mounting is carried out by two persons.

Use the supplied screws.

Unpacking

Unpack the heating unit.

Note!

During transport the side panels and brace are placed in the back of the machine (A).

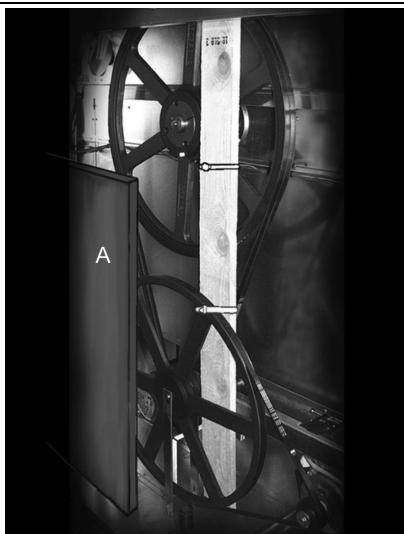

fig.W00142A

Mounting the heating unit

Remove the top panel for the heating unit from the top of the machine where it is placed during transport.



fig.W01153

Demount the two top back panels on the machine.

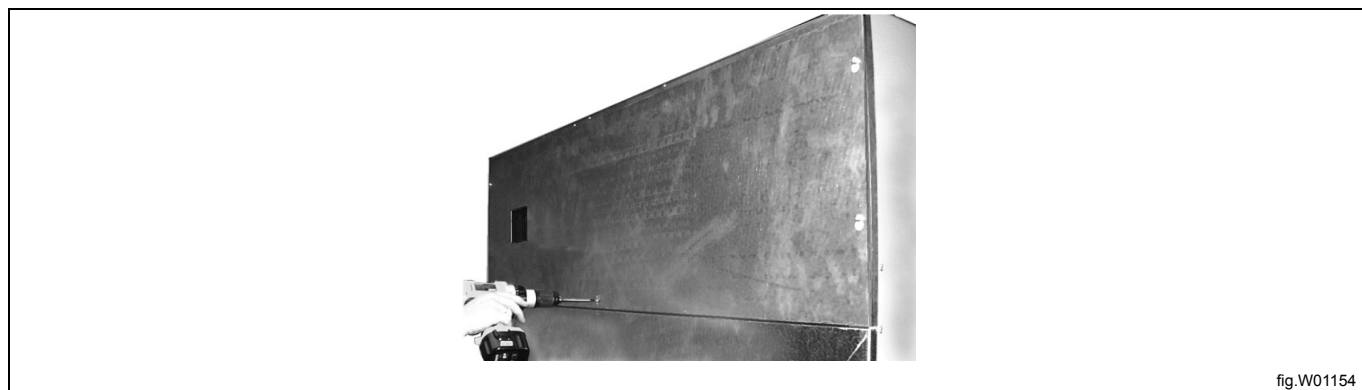

fig.W01154

Lift the steam calorifier and place it on top of the machine.



fig.W01180

Fasten the steam calorifier with 5 screws on both sides.

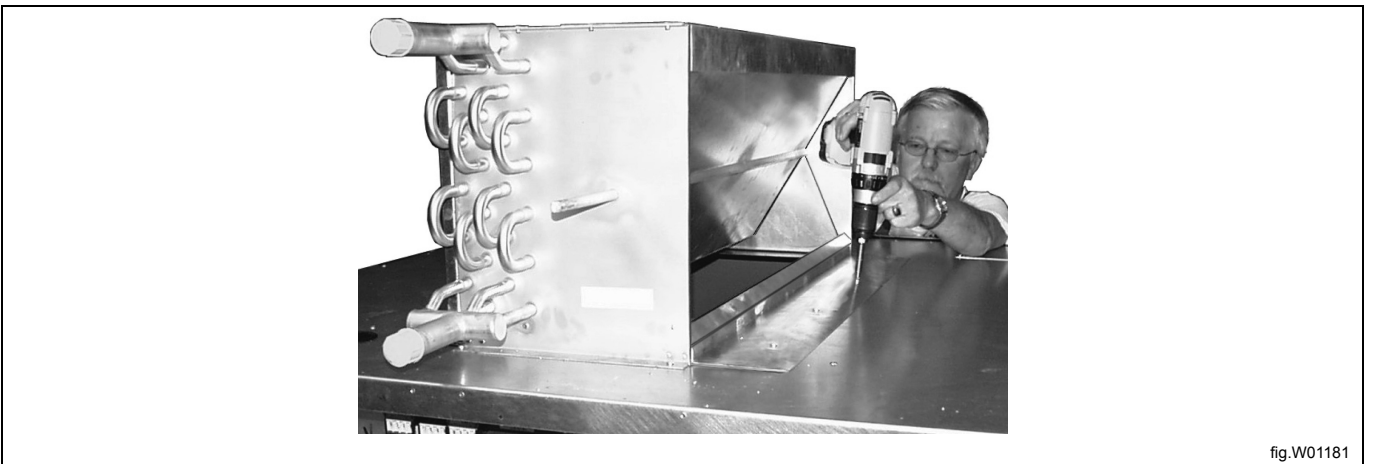

fig.W01181

Place the actuator box so that the end of the shaft from the steam calorifier is lead into the hole in the actuator.

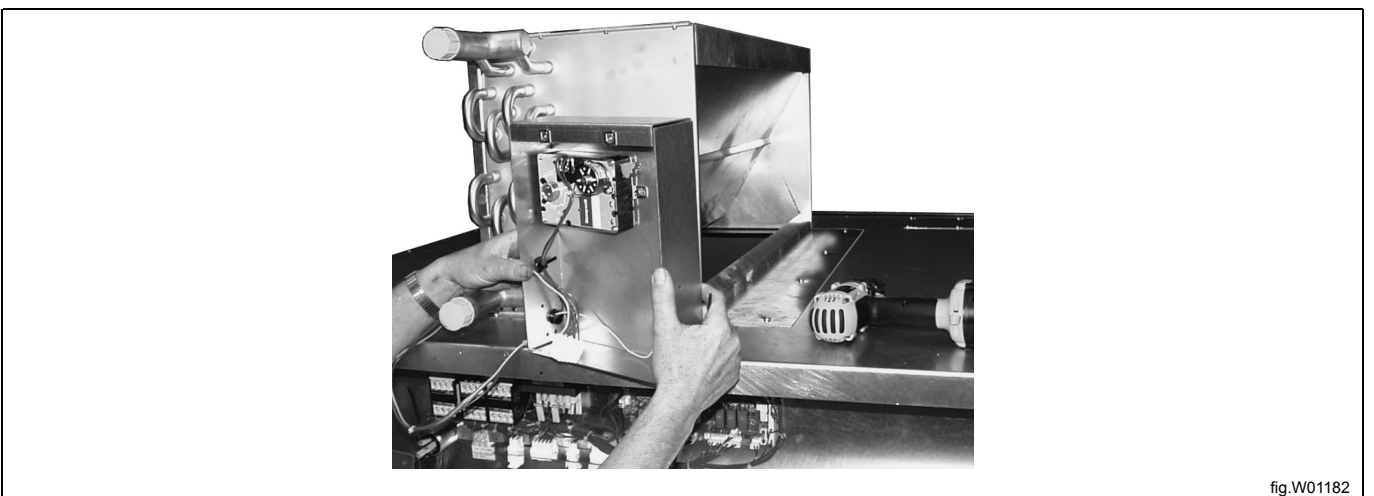

fig.W01182

Note!

When tightening the end of the shaft the damper must be open (B).

Using two tailstock screws tighten the end of the shaft (C) to 5 Nm with a 1/8" Allen key (Note! It is a 1/8" key, not a mm key).

It is possible to adjust the damper opening by turning the manual declutch lever (D).

A = damper closed, B = damper open.

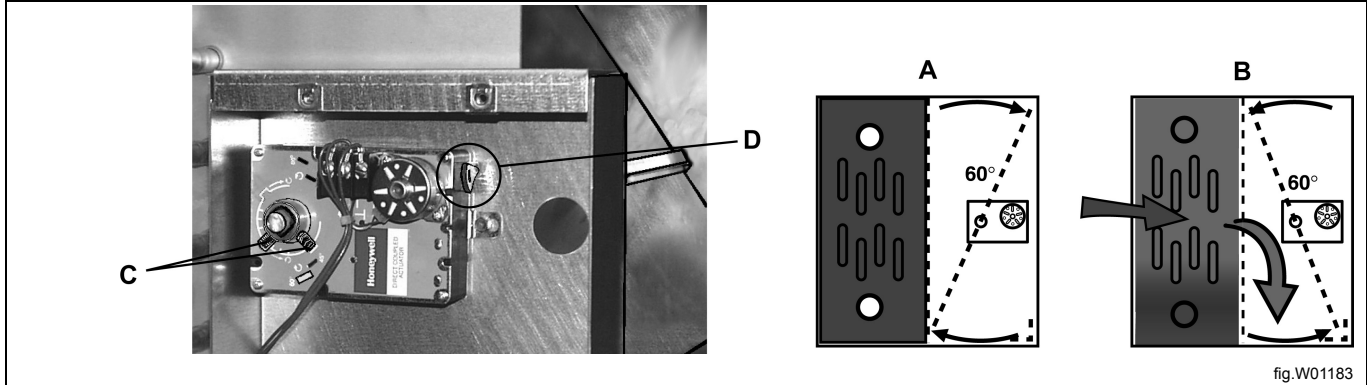

Mount the supply disconnector, which is mounted on the console, in its place on the component unit using 4 screws. Place the multiple plug in connector marked *A*.

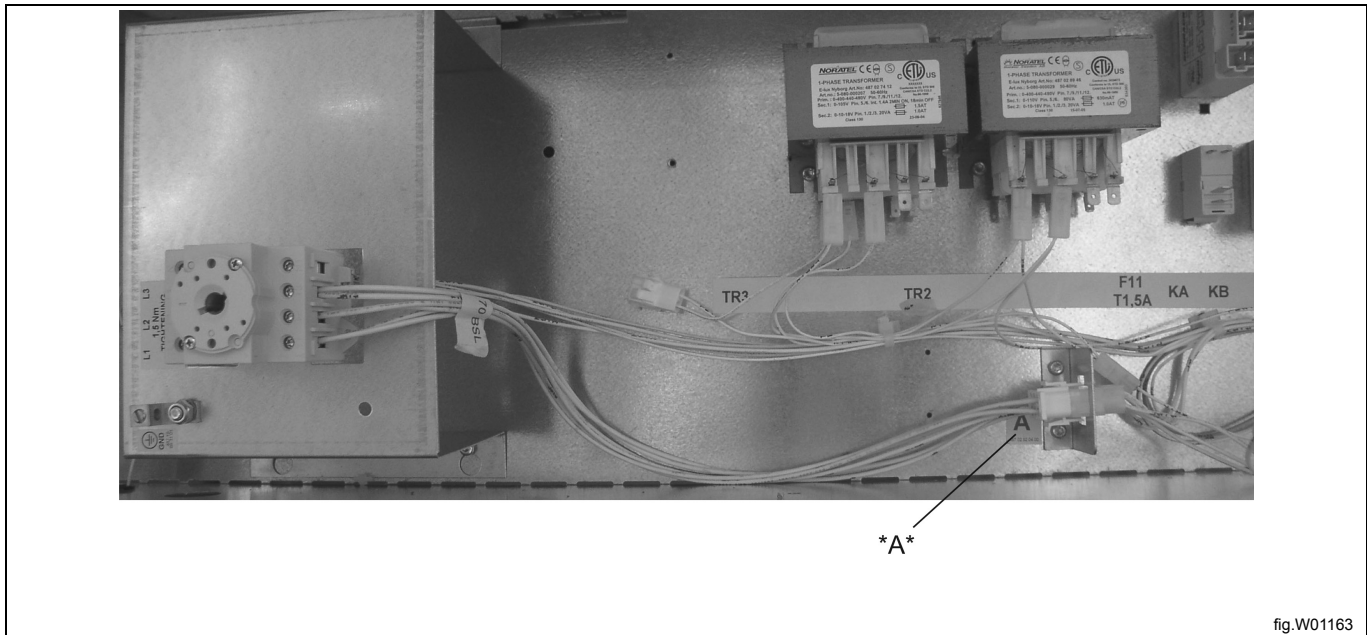

Lead the multiple plug from the actuator box down through the cable gland to the component unit and place it in connector marked *B*. Strap the wires according to the figure.

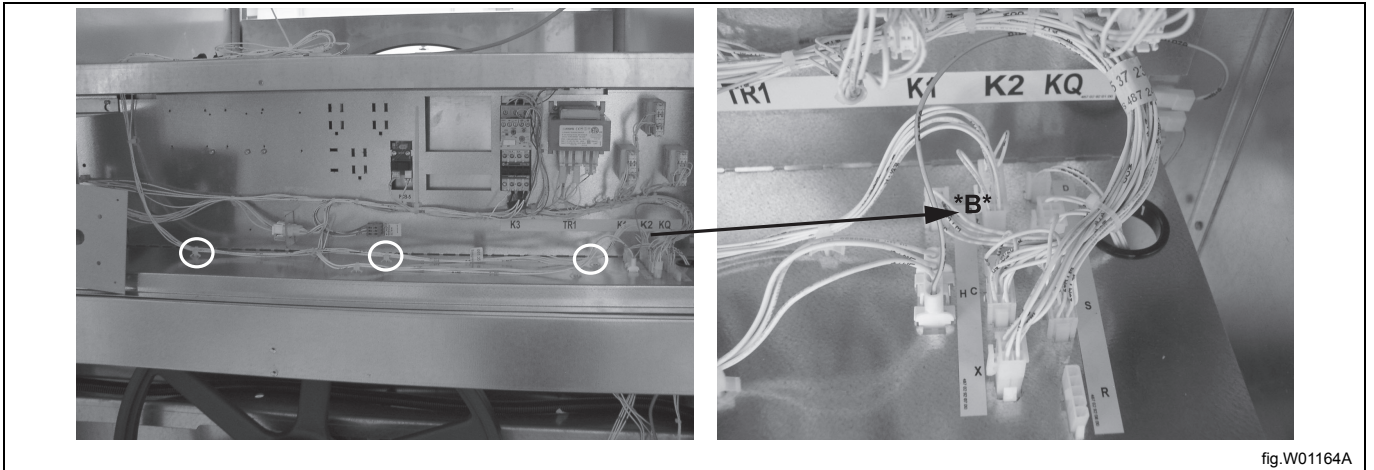

fig.W01164A

Place the supply disconnecter panel with handle in its place.
For more information, see section "Electrical connection".

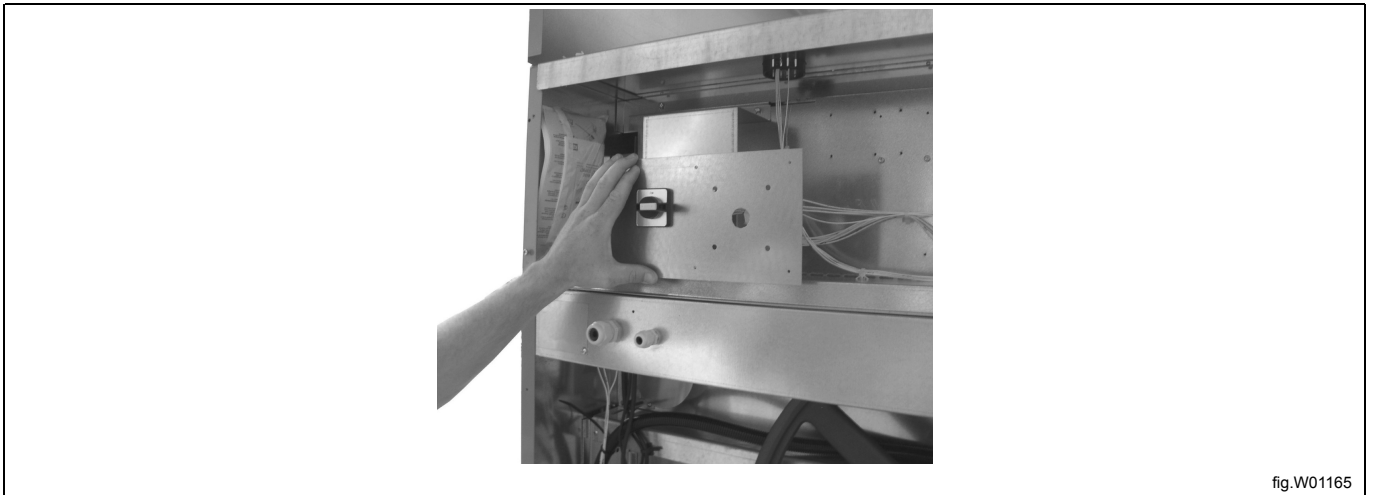

fig.W01165

Mount the two back panels. When mounting the component unit back panel its top edge must be tilted under the basic machine's top panel.

It is possible to mount the wires from the installation before mounting the back panel.

Screw the supply disconnecter panel with handle into the back panel using 6 screws.

Note!

Check that the supply disconnecter can connect and disconnect the power.

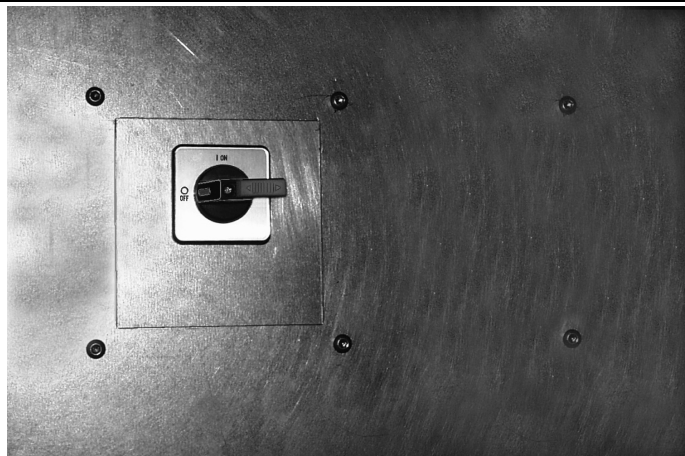

fig.W01167

If the machine has sliding door, go to section "Mounting equipment for sliding door", before carrying out the next step. Mount the brace (H) right above the front panel and fasten it using 6 screws.

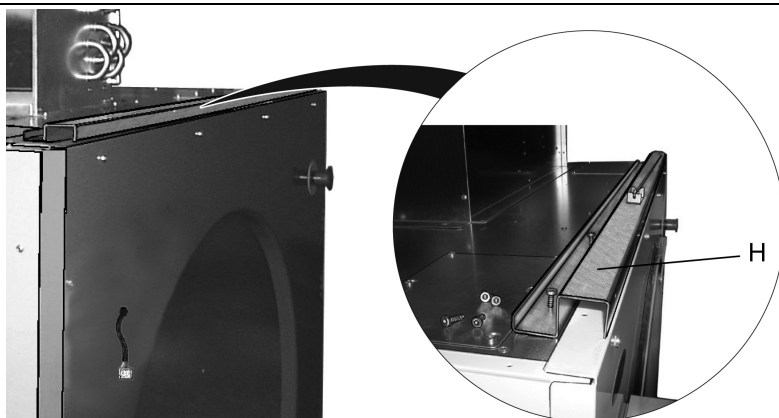

fig.W01184

Fasten the side panels to the bottom using 5 screws on each side as follows:

First fasten the front screw and the back screw but not all the way down. Turn the side panel with the grooves facing downward and mount the side panel in the grooves. Tighten the screws.

Fasten the last 3 screws.

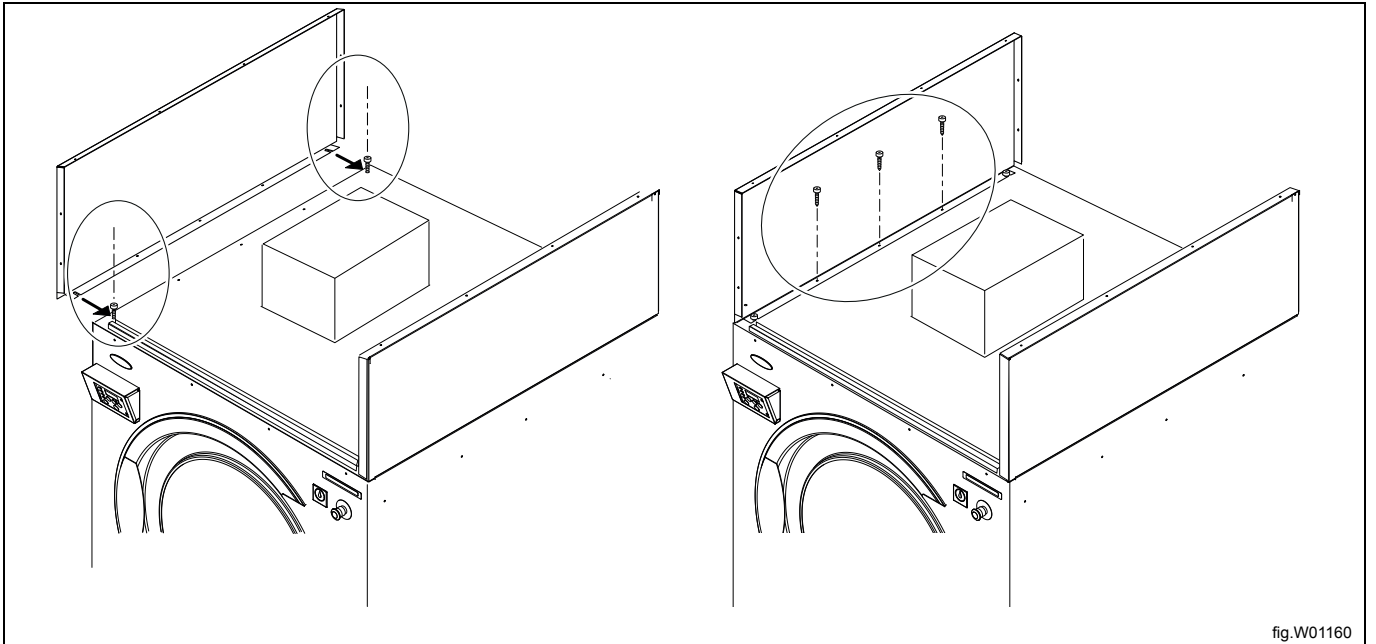

fig.W01160

Position the air maze.

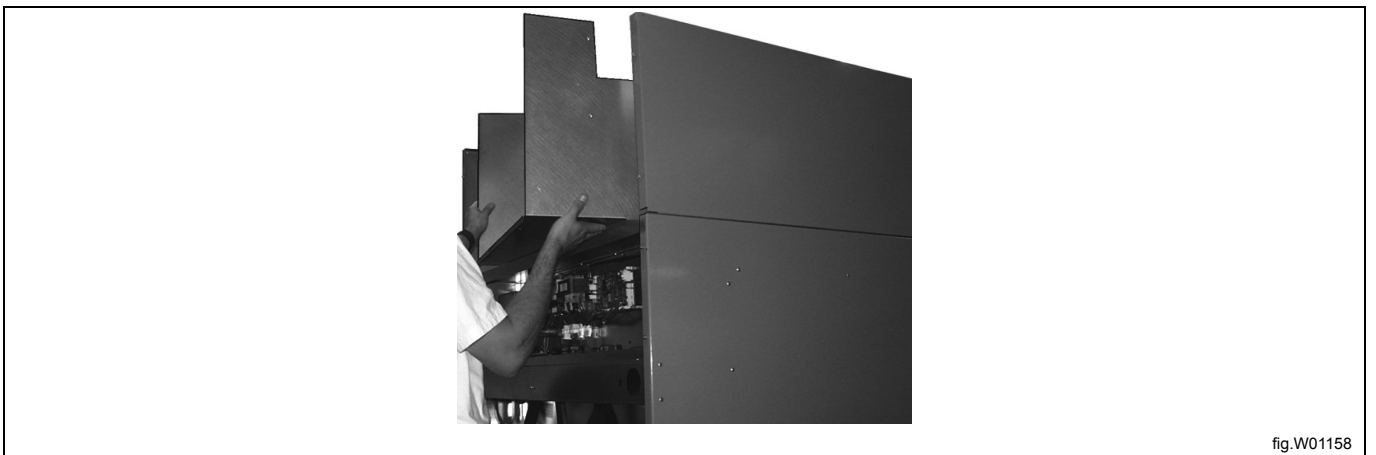

fig.W01158

Position the top panel.

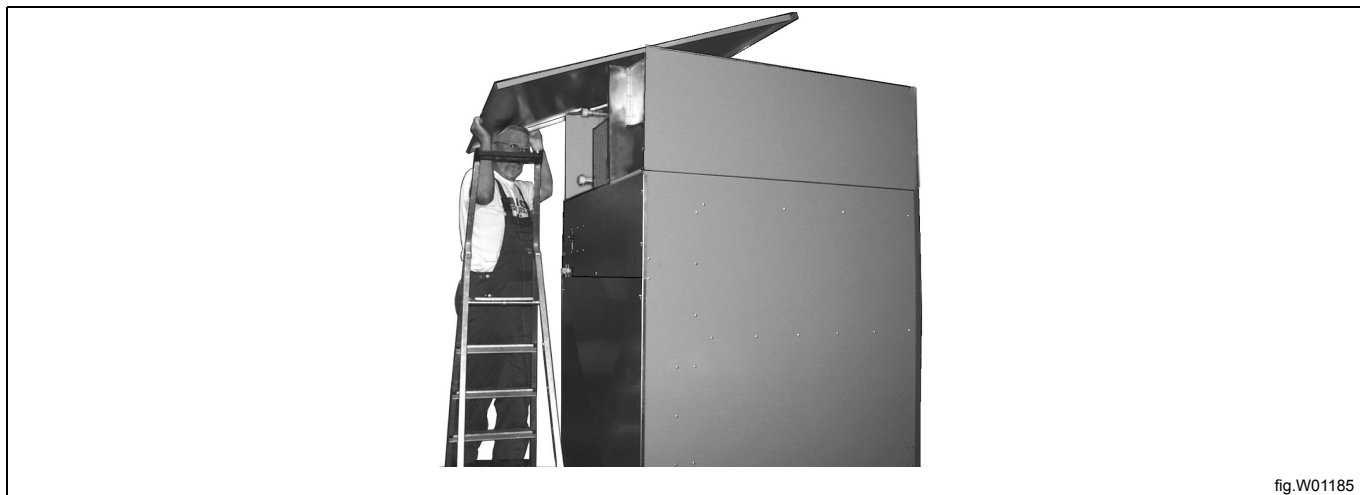

fig.W01185

Fasten the maze using 2 screws.

Fasten the top panel using 4 screws on each side.

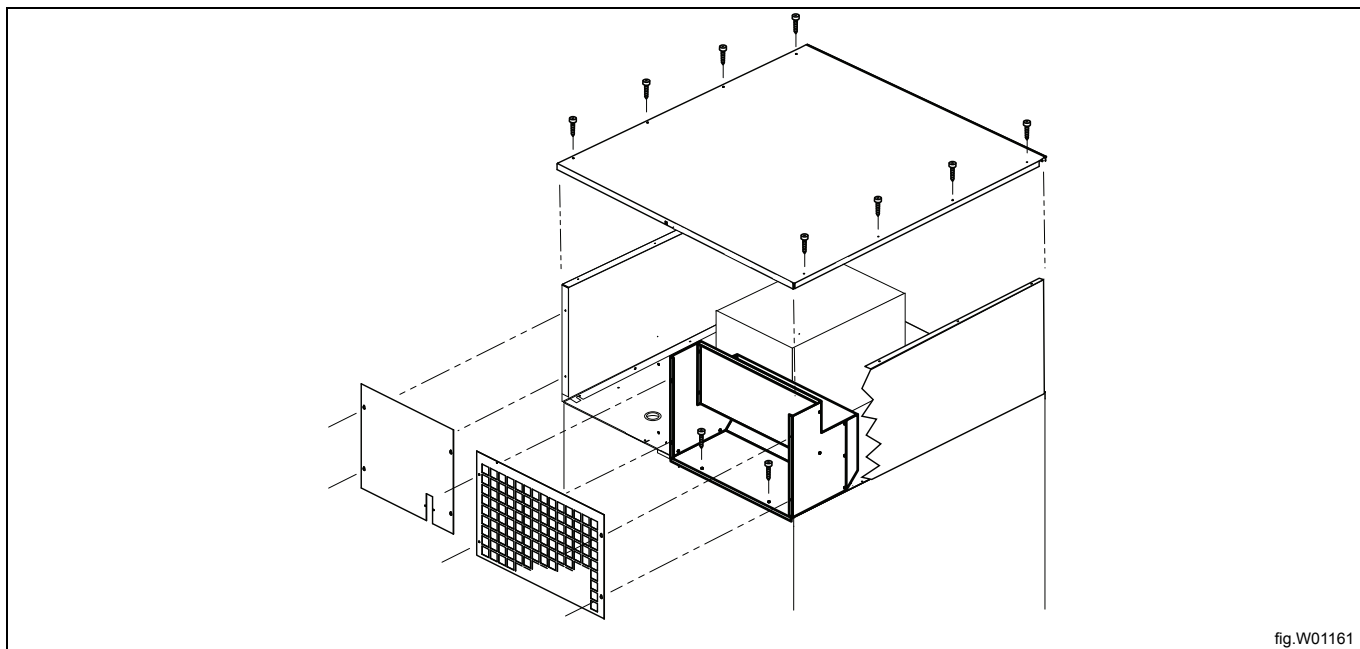

fig.W01161

Mount the front shutter using 2 screws and locking nuts.

Mount the support plate (I).

Lock the front shutter on the front using 2 screws.

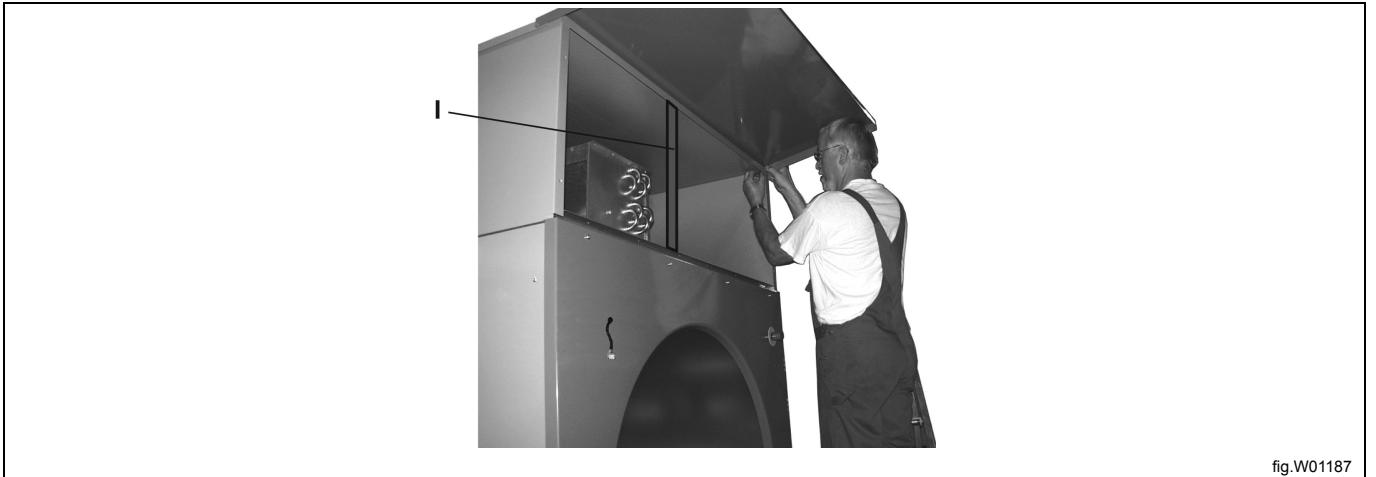

fig.W01187

Mount the back panels of the heating unit (E).

When mounting the component unit back panel (G) its top edge must be tilted under the basic machine's top panel.

E: 2 back panels: Heating unit (6 screws)

F: Top panel: Basic machine

G: Back panel: Component unit (6 screws)



fig.W01166

Connect the steam.

For more information, see section "Steam connection".

J = Inlet

K = Return (condense)

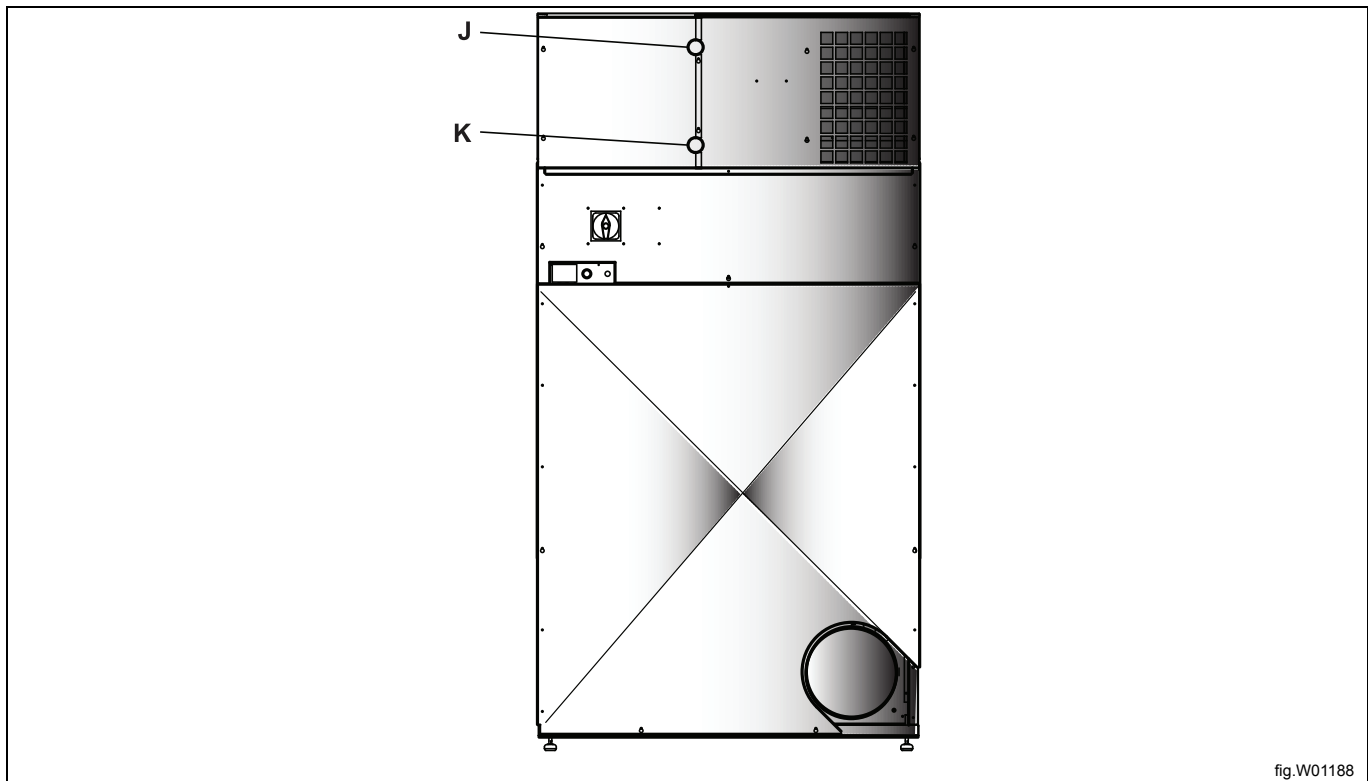

8.4 Mounting equipment for sliding door

Mount the brace (A) using 6 screws. Mount the 2 angle braces (B) using 2 screws in each one.

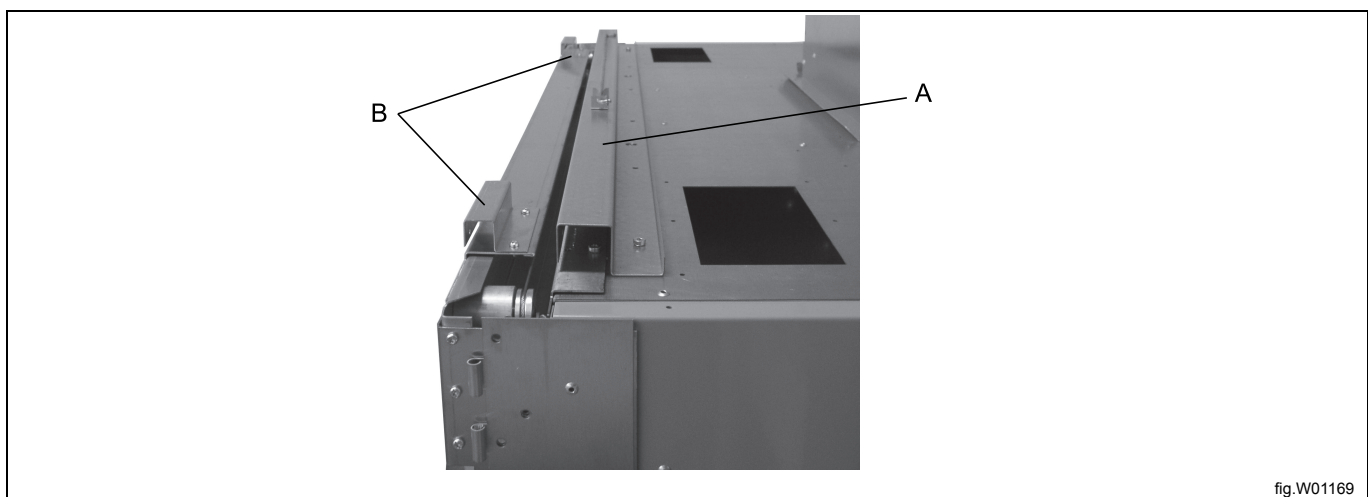

Mount the side panels (C) from above and push them down as far as they will go.
 Mount screws (D) in order to lock the side panels (1 screw on each side).

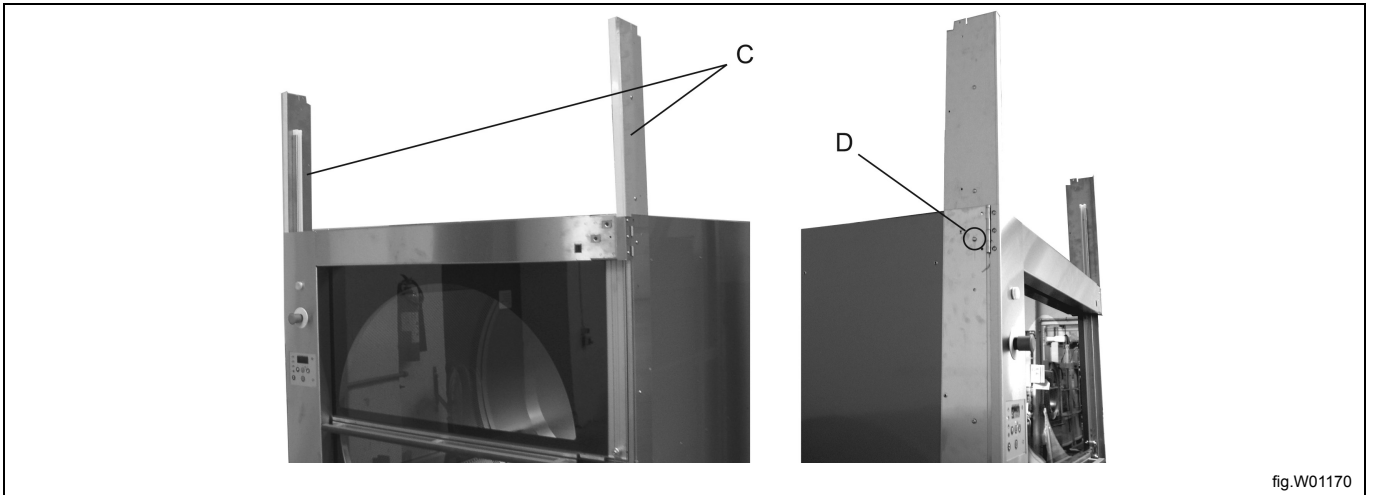

fig.W01170

Mount the side panels and the remaining as described in “Mounting heating unit”.
 Check that the doors slide open easily.

Note!

It is important that the mounting is carried out carefully, vertical and level as this influences the movement of the sliding door.



fig.W01171

9 Installation of tilting unit

9.1 Contents

Description	Art. No.	Pcs	ID in this instruction	Comment
Left mounting base	487242771	1	A	With 2 foundation feet (F)
Right mounting base	487242770	1	A	With 2 foundation feet (F)
Mounting base front	487243655	1	B	
Mounting base back piece	487243755	1	C	
Adjusting plate 1 mm	487242725	5	D	
Adjusting plate 2 mm	487242726	5	D	
Adjusting plate 3 mm	487242727	5	D	
Expansion bolt	471830102	8		M8 x 120 for fastening in the floor
Bolt	487242778	2	E	M20 x 30
Washer	487242777	2	E	M20
Console	487242605	2	E	For front foundation foot
Shouldered bolt	487242779	2	G	M10 x 80, lock for front foundation foot
Locking nut	732212001	2	G	M10, lock for front foundation foot
Actuator	487028988	2	H	
Centre bolt	487242799	4	J	M8 for clamping actuator
Locking nut	732211801	4	J	M8 for clamping actuator
Bevel washer	734116431	4	J	M8 for clamping actuator
Left side skirt	487242788	1	M	
Right side skirt	487242775	1	M	
Clip screw	487242796	8	Mm	M5 for mounting in side skirts
Nut	731231401	8	Mn	M5 for clip screws in side skirts
Back skirt	487240222	1	O	
Front cross bearer	487240221	1	N	Front skirt
Top nut	487242797	4	Q	M5 for back skirt
Plate screw	487226074	12		4.8 x 13 (Torx)
Connecting piece	487240611	1	L	For outlet pipe 315 mm — 303 mm / 12"
Bits extension piece	487242254	1	LI	For mounting outlet pipe

9.2 Installation

The machine shall be mounted on a concrete floor with a thickness of at least 100 mm / 3 15/16 inch. Make sure the floor is in level.

Place the 2 mounting base sides (A) (fastened on wooden pallet with 4 transportation screws which should be removed) on the concrete floor, where the machine is going to be mounted.

The mounting base sides must be lowest at the machine front.

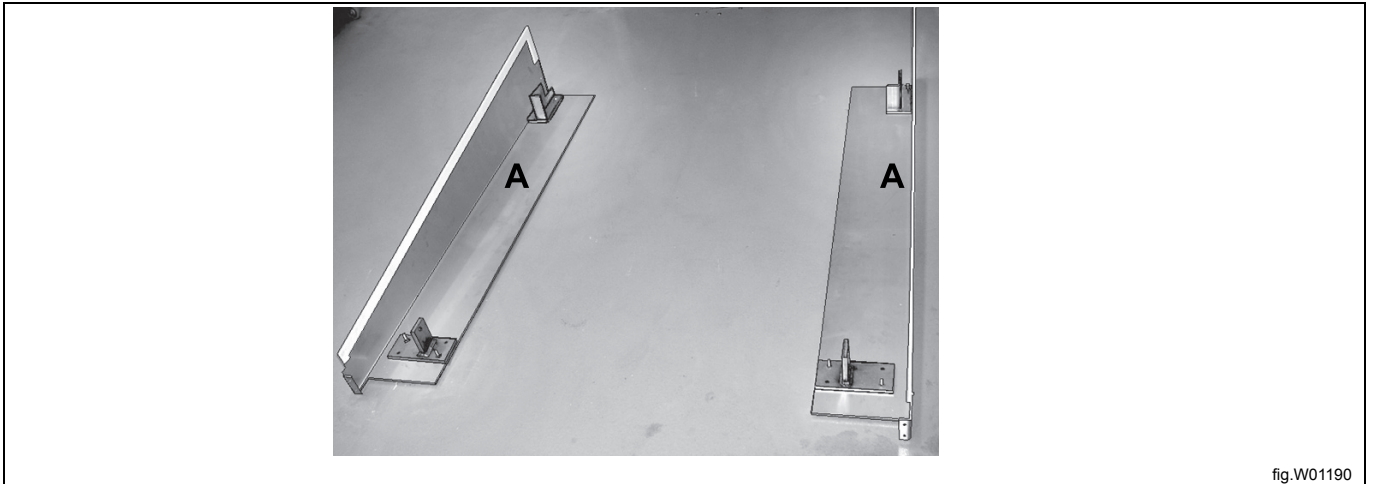

fig.W01190

Mount the mounting base front piece (B) and the mounting base back piece (C) on the mounting base sides.

Make sure that the mounting bases are in level. Cross measure between the foundation feet (F) making sure the mounting base is square.

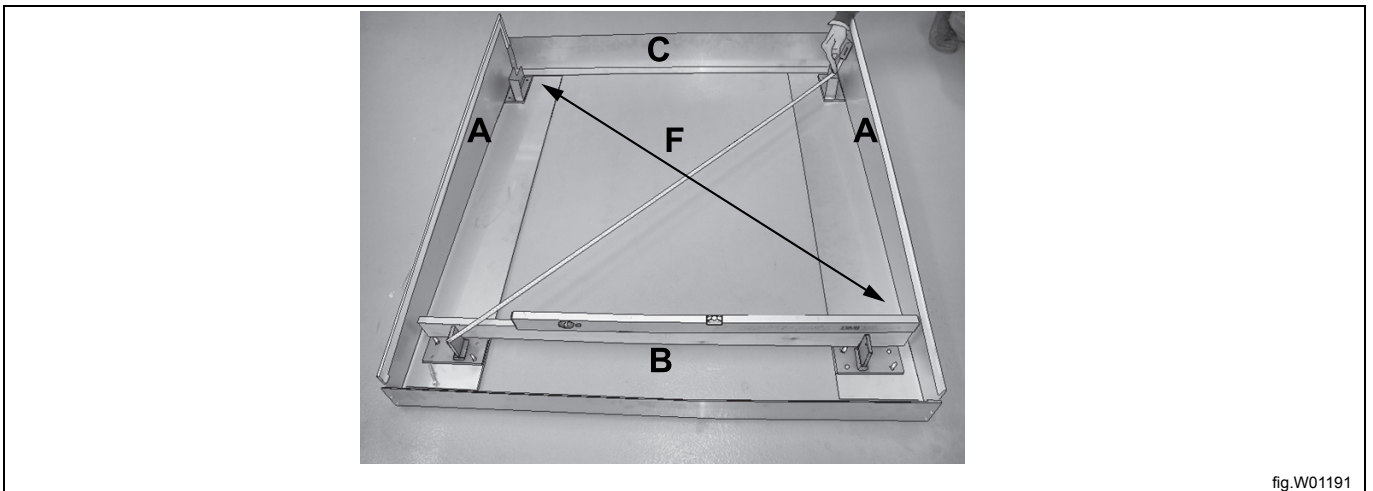
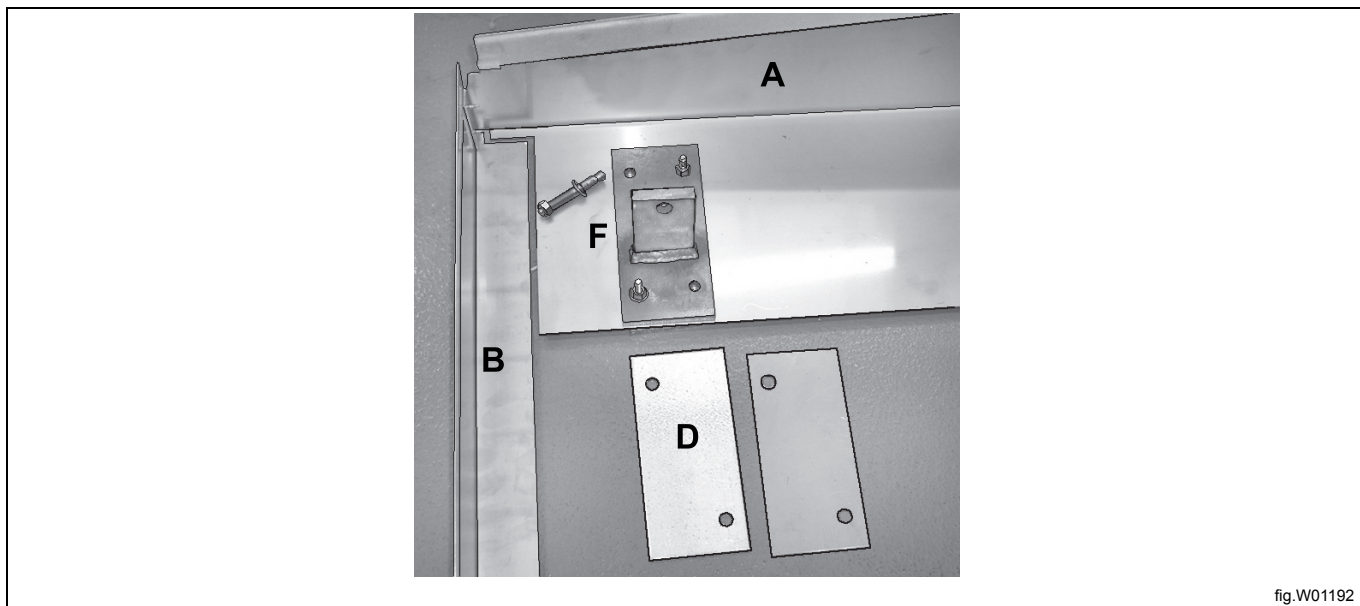

fig.W01191

For alignment, use the adjusting plates (D) as an underlying layer.



Mark out the 8 holes (to be drilled with an 8 mm concrete drilling machine).

After fastening all 8 expansion bolts, dismantle the mounting base front piece (B) and the mounting base back piece (C).

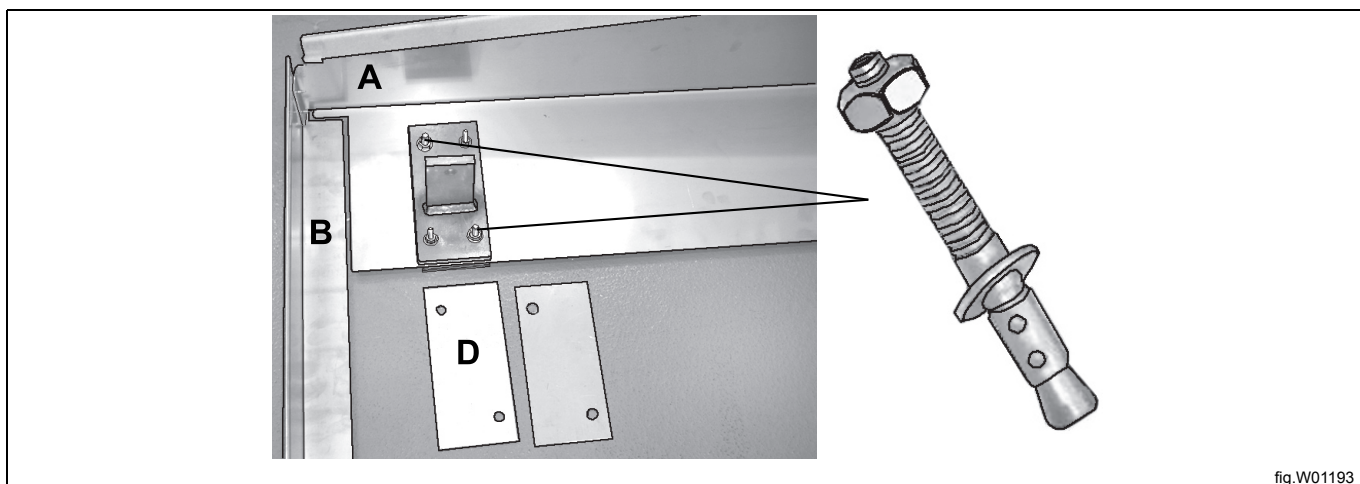

After the fastening is done, carry out the control measuring. The mounting base must be diagonally level and the mounting base sides must be parallel.

It is important to be careful when aligning the mounting base.

If necessary use adjusting plates (D).

Note!

If the mounting base is crooked the sliding door and the tilting function will not work properly.



Loosen the 6 wood screws (2 at the front and 4 at the back) which are holding the battens.

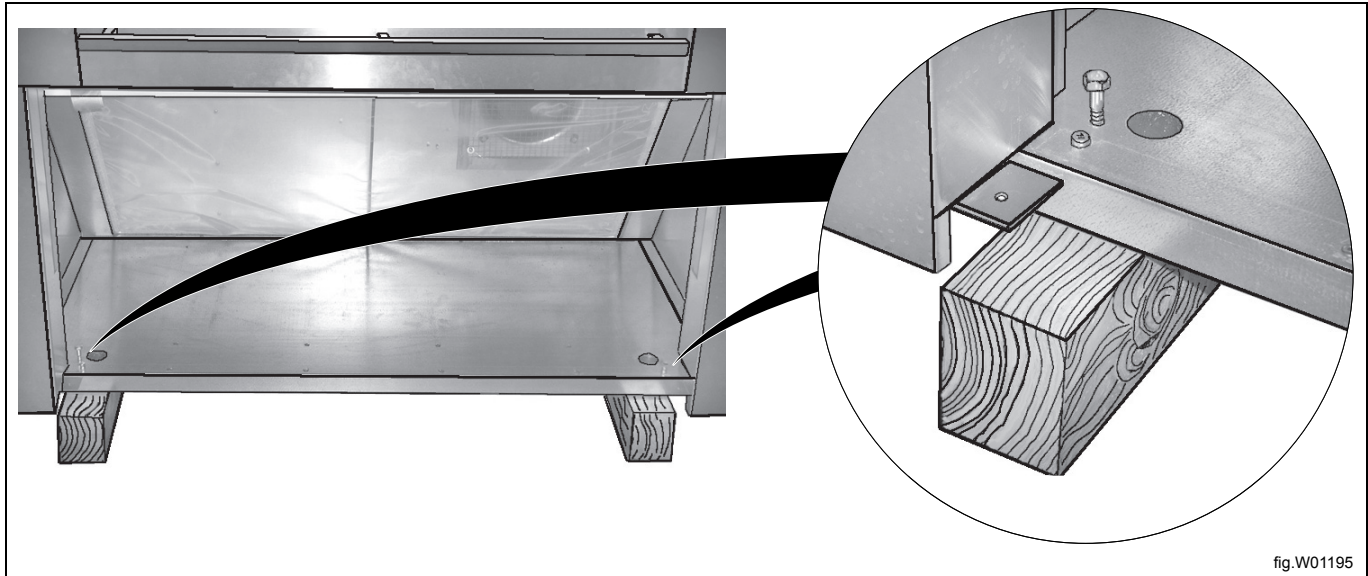

fig.W01195

Use a lifting truck to lift the machine and remove the battens.

Note!

Be careful when lifting and make sure the fork arms are placed exactly under the middle of the machine in order to be in equi-poise.

Assemble the 2 front guiding consoles (E) with the foundation bolts M20 E. Do not tighten the bolts.

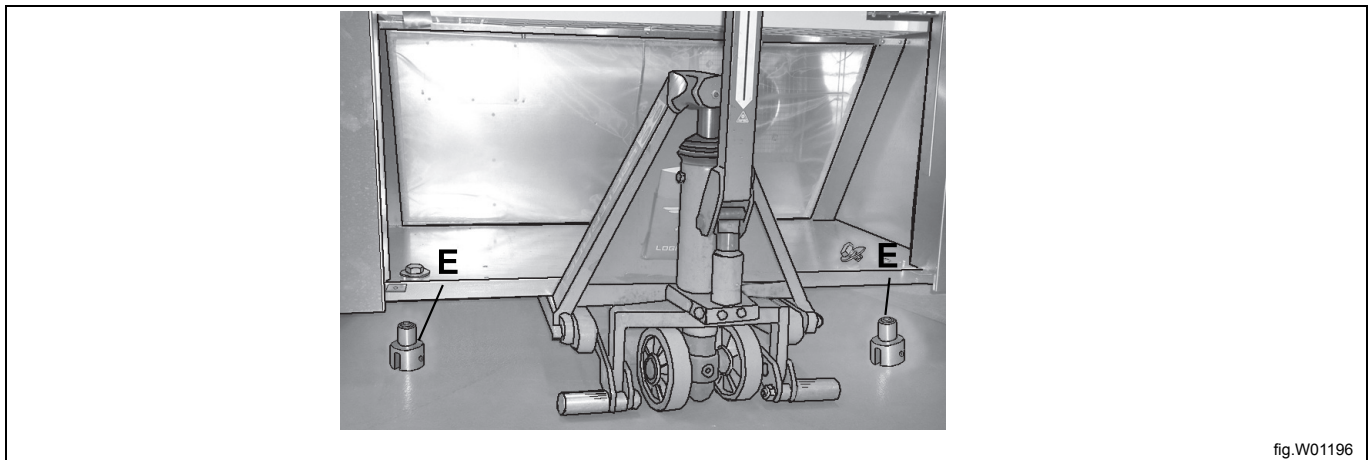

fig.W01196

Push the lifting truck so the machine is above the 2 mounting base sides.

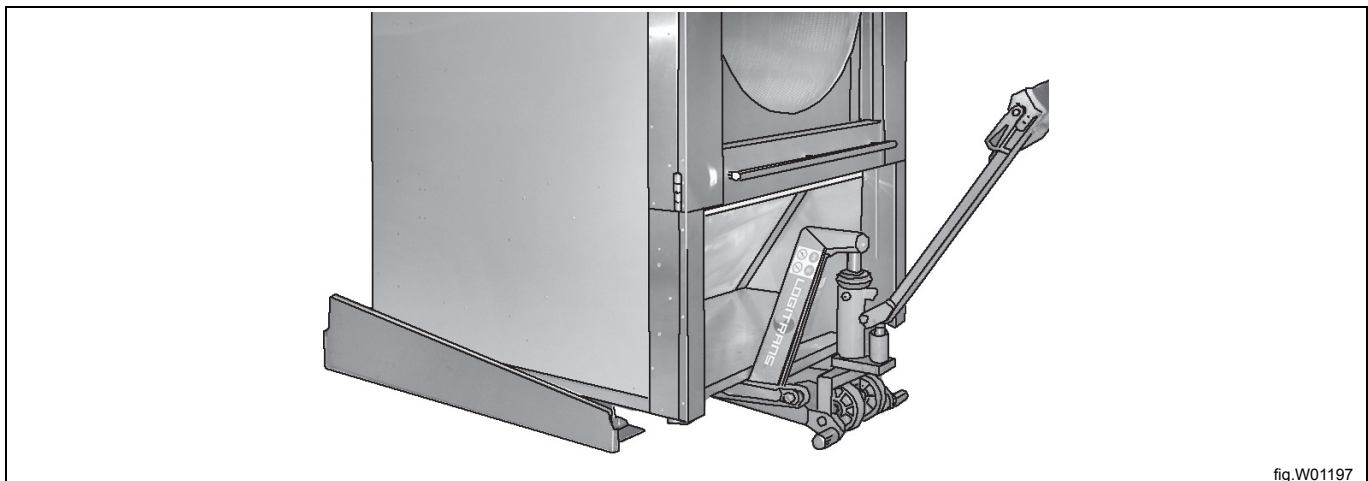

fig.W01197

Lower the machine so the guiding consoles (E) engage with the foundation feet (F).

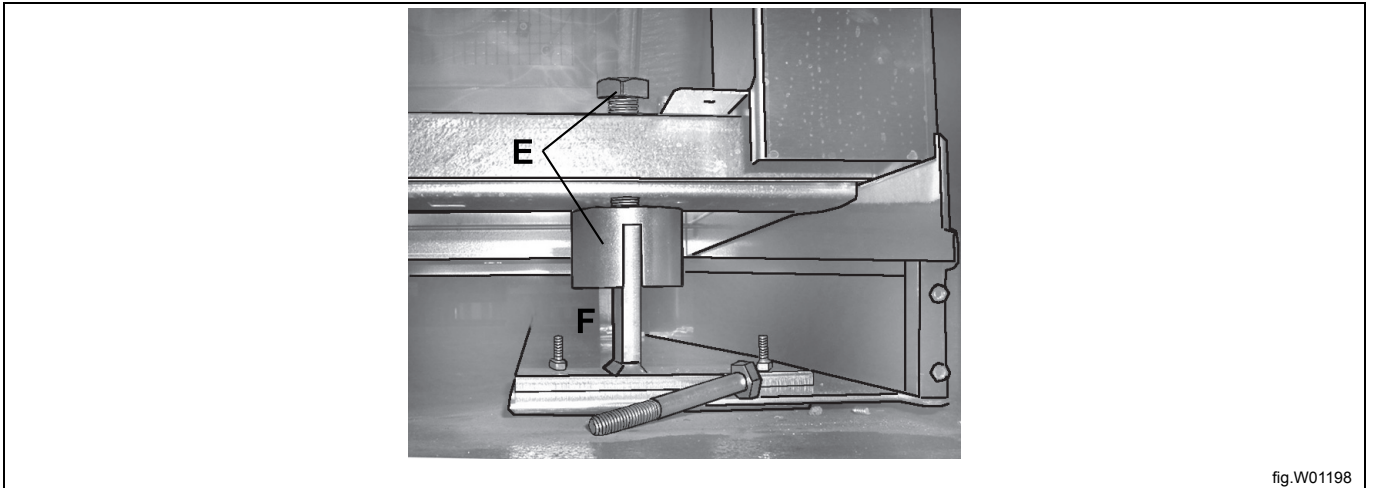

fig.W01198

Insert the 2 locking bolts (G) and tighten them.

Lower the lifting truck all the way down.

The transportation bearers (only used during transport) are now resting on the lifting truck fork arms and are pulled out.

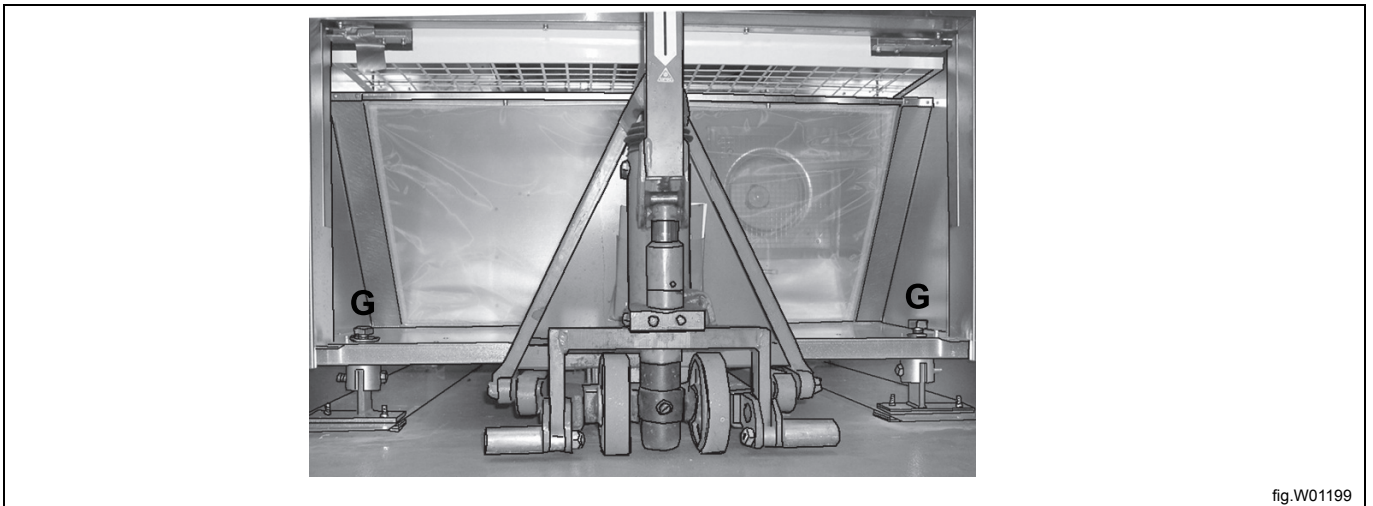

fig.W01199

Tighten the 2 foundation screws (E) and mount the mounting base front piece (B).

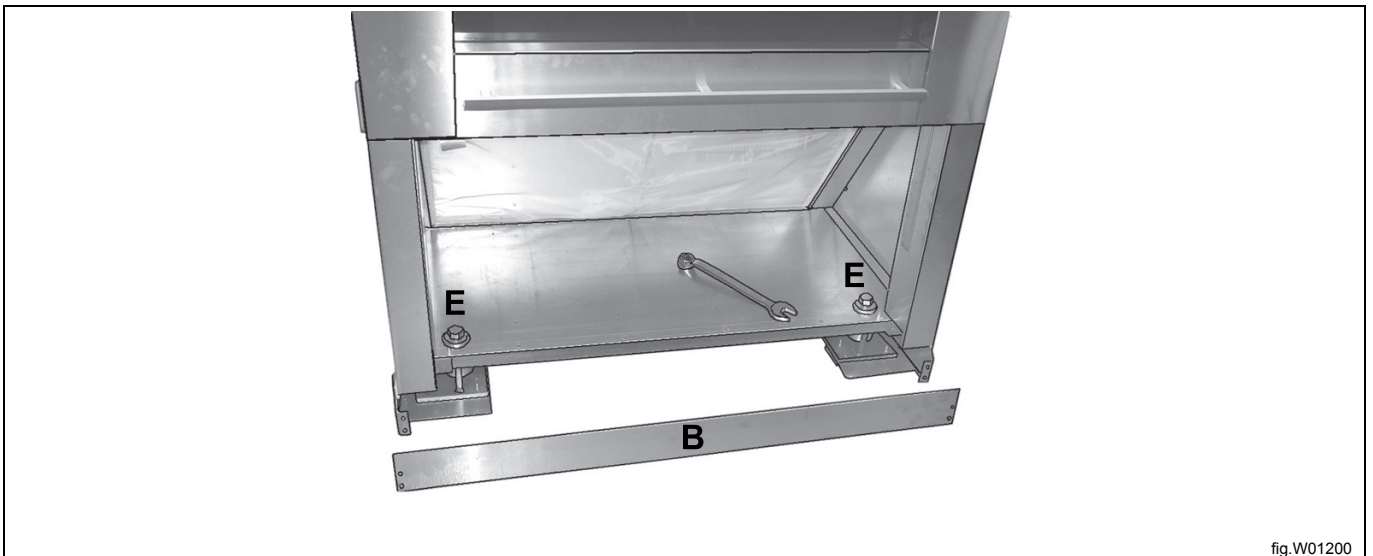
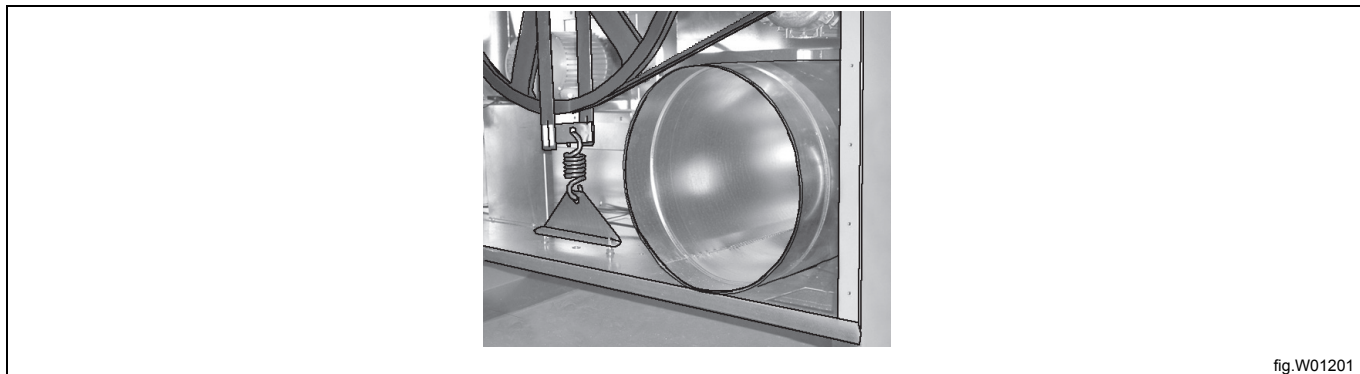
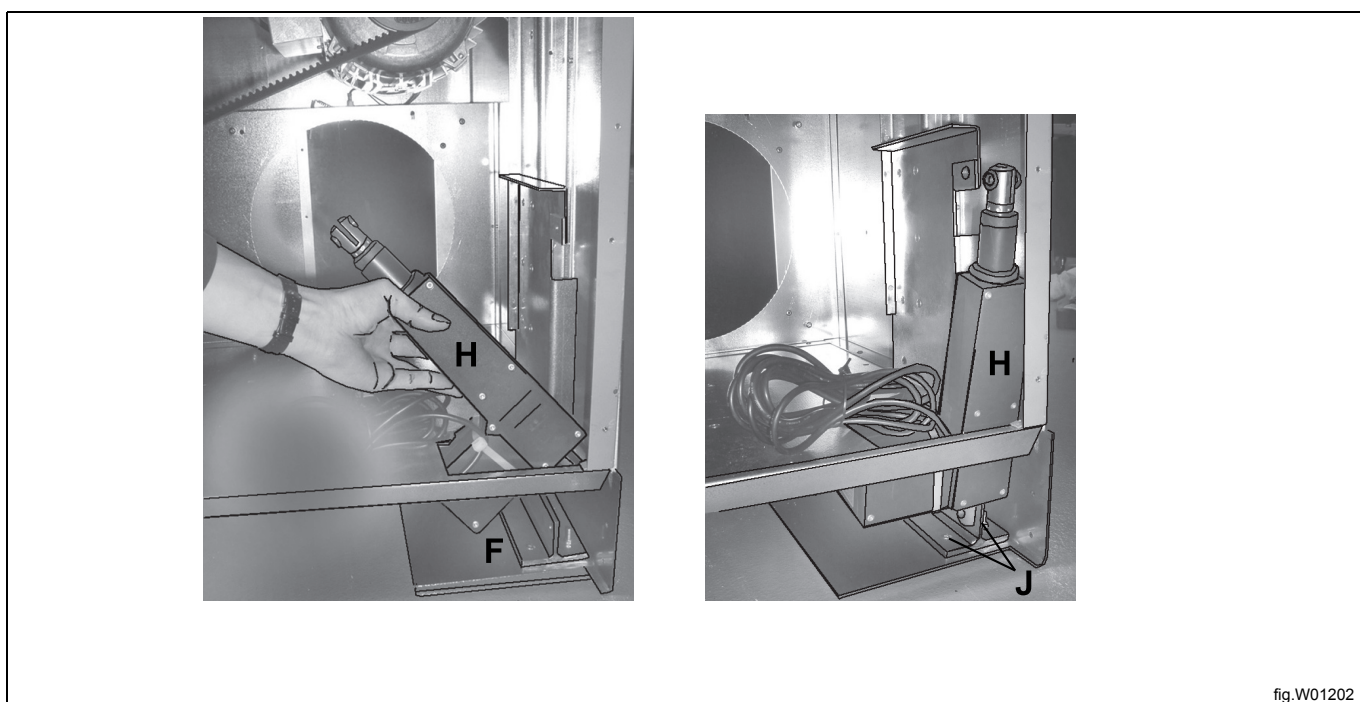

fig.W01200

Dismount the outlet pipe. Use the supplied bits extension piece (LI) for dismantling the outlet pipe.



Mount the 2 actuators (H) on the back foundation feet (F) by tilting them through the 2 square openings. Fasten the actuators with 2 centre bolts (J), washers and locking nuts.



Fasten the actuator wires with the pre-mounted cable ties (Hh).

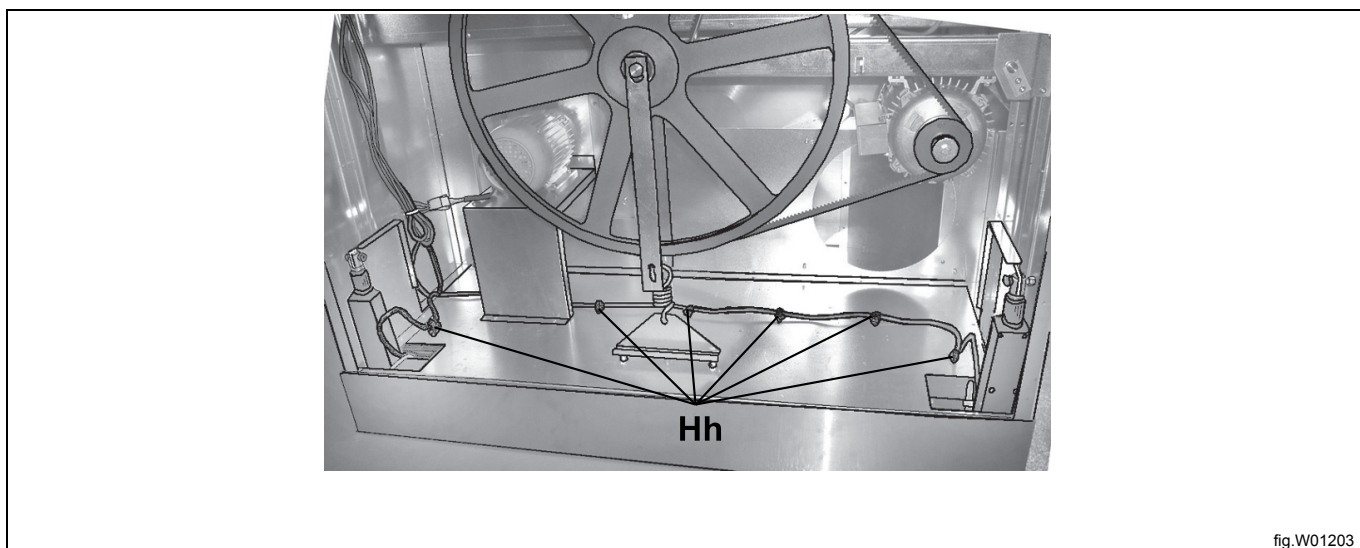

Place the 2 multiple plugs (K) from the actuators in the control box.

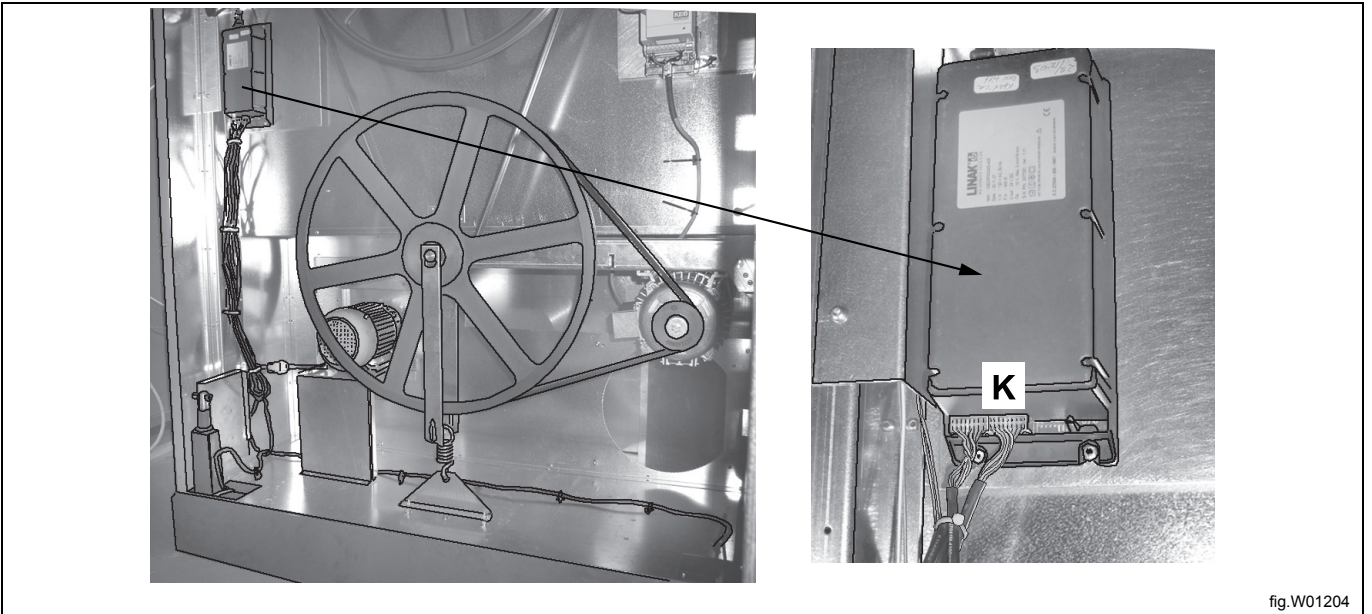

fig.W01204

Mount the back mounting base piece (C).

Mount the outlet pipe and connecting piece (L). Use the supplied bits extension piece for mounting the outlet pipe.

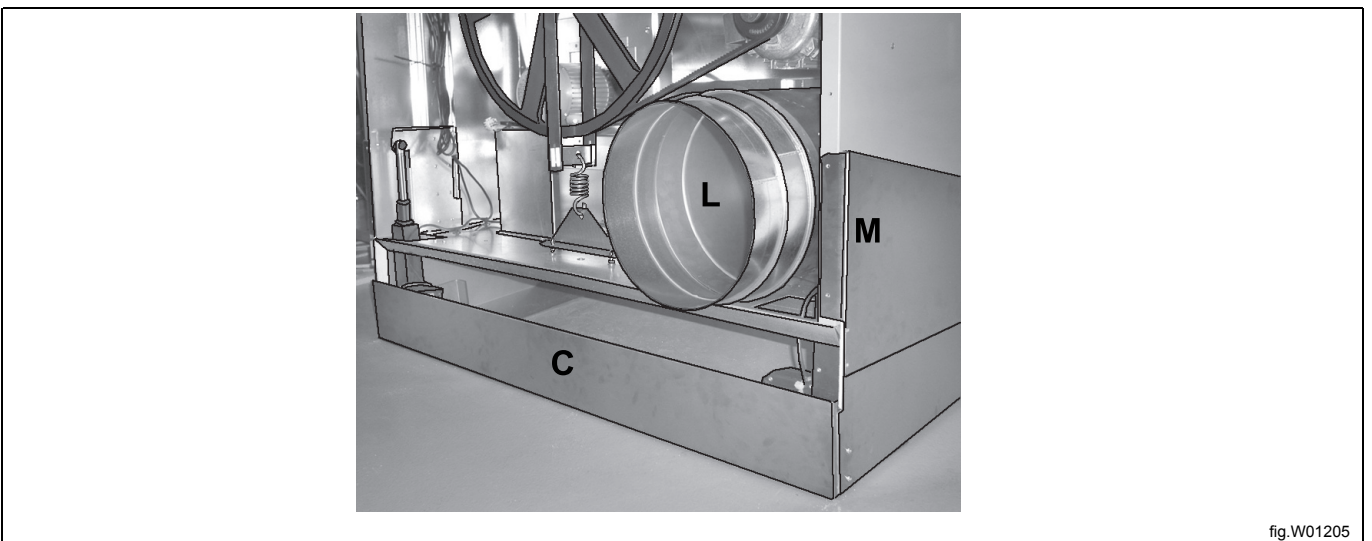
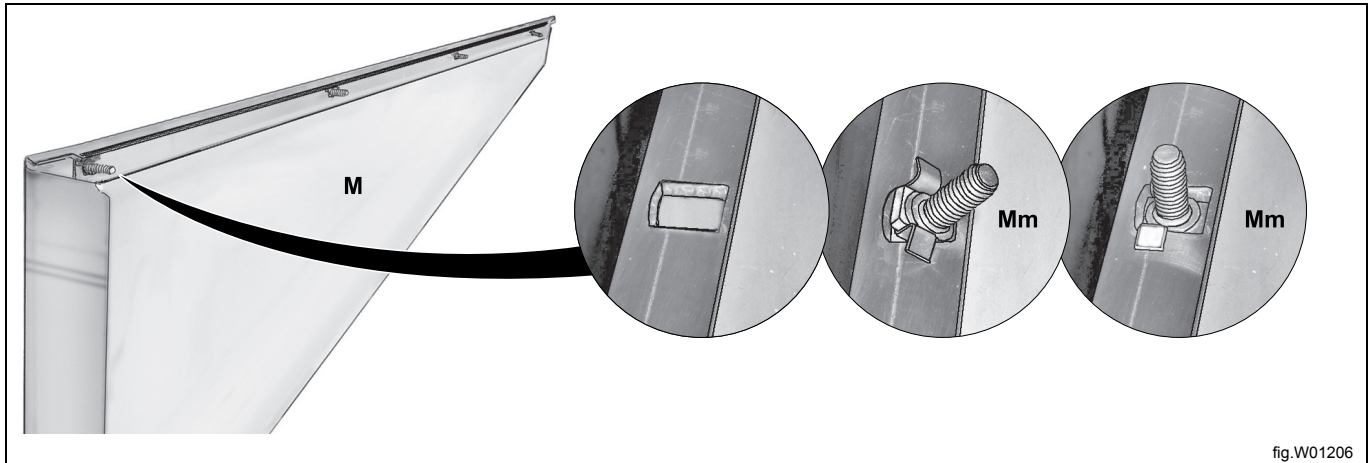

fig.W01205

Mount 4 clip screws (Mm) in both side skirts.

Insert the clip screws diagonally into the square openings and push them down.



Mount side skirts (M) and cross bearer/front skirt (N).

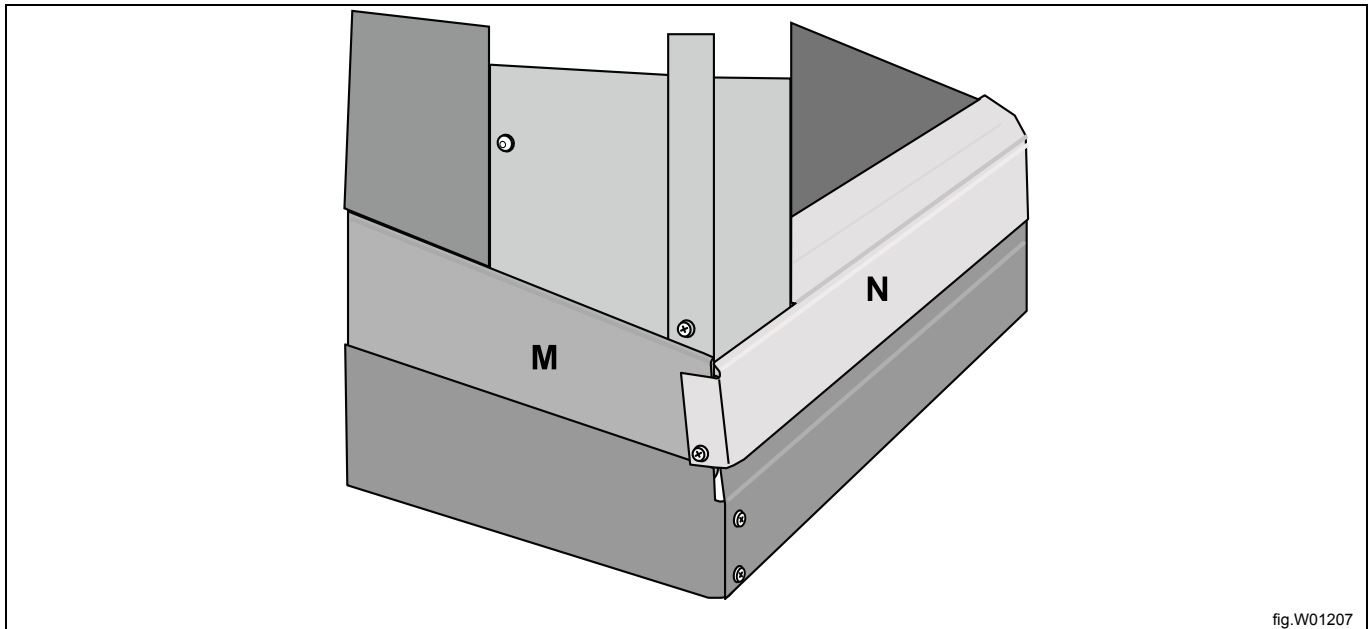

Remember to mount 4 nuts (Mn) in each side to hold the skirts.

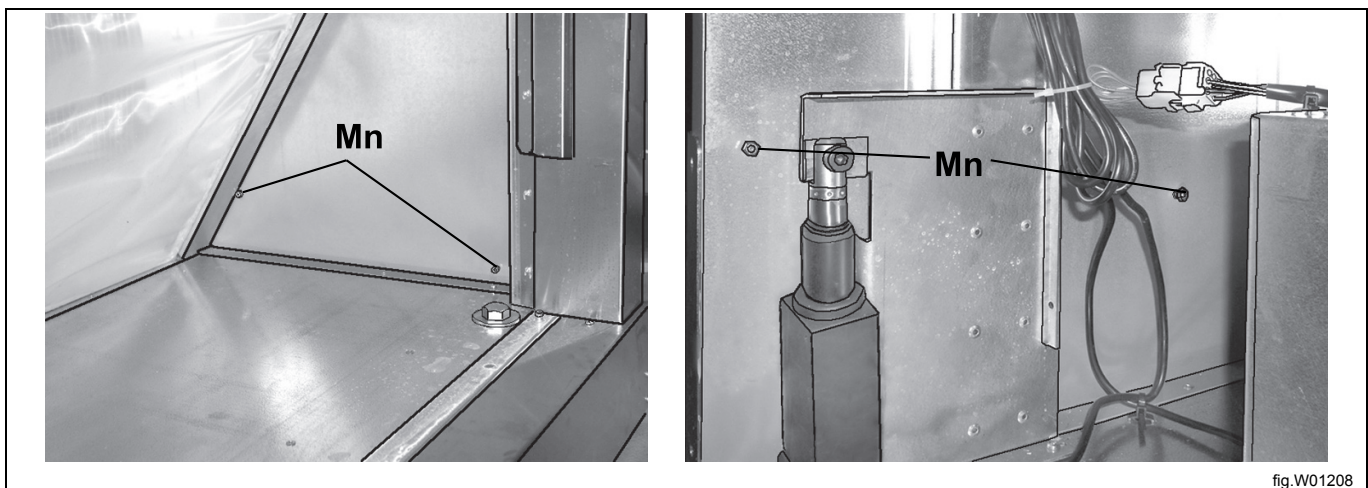

Mount the back skirt (O) with 2 screws (P) and 2 top nuts (Q).

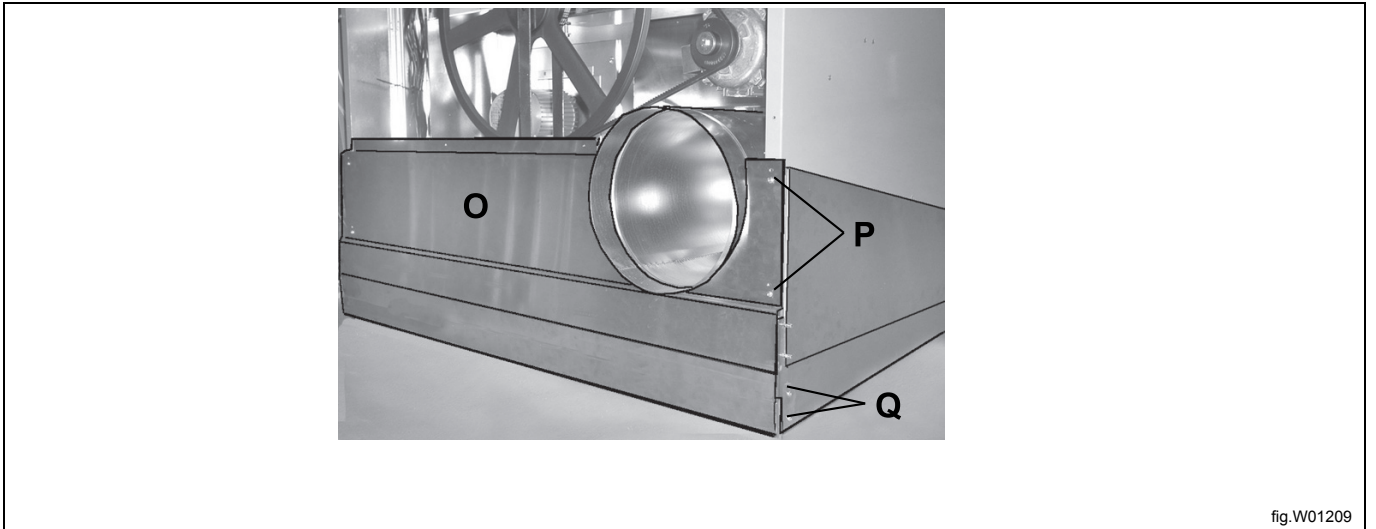

Mount the big back plate (R).



When ready; the figure shows the machine in tilted position.



fig.W01211

10 Function check



May only be carried out by qualified personnel.



A function check must be made when the installation is finished and before the machine can be ready to be used. Whenever a repair has been made, a function check must be performed before the machine can be used again.

Check the automatic stop of the machine

Start the machine.

- Check if the micro switches are working properly:
- The machine must stop if the door is opened.
- The machine must stop if the filter door is opened.

Check the direction of rotation (only on machines with 3-phase power supply)

Correct direction of rotation on blower wheel:

- The blower wheel must rotate clockwise.
- If the direction of rotation is not correct, swop two phases on the connection terminal.

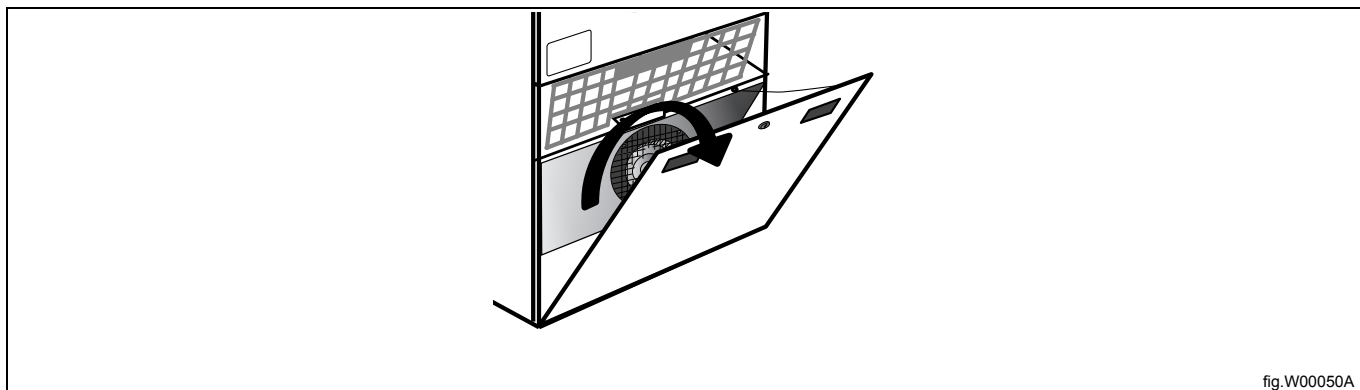

fig.W00050A

Check the heat

- Let the machine work for five minutes on a program with heat.
- Check that the heating is working by opening the door and feel if there is heat in the drum.

Tilt

Check the tilt function.

Sliding door

Sliding door must be capable of being opened with a force of max 10 kg / 98N.

Ready to use

If all tests are OK the machine is now ready to be used.

If some of the tests failed, or deficiencies or errors are detected, please contact your local service organisation or dealer.

The installer shall instruct the user on the operation of the appliance before leaving.

11 Adapter for direct fresh-air intake

1	Adapter kit no. 988 800 0003 - Steam heated machines
2	Adapter kit no. 988 800 0004 - Gas and electric heated machines
3	Connecting branch in top / bottom for fresh-air intake, \varnothing 315 mm / 12 3/8 inch

A = Standard machine

B = Machine with sliding door

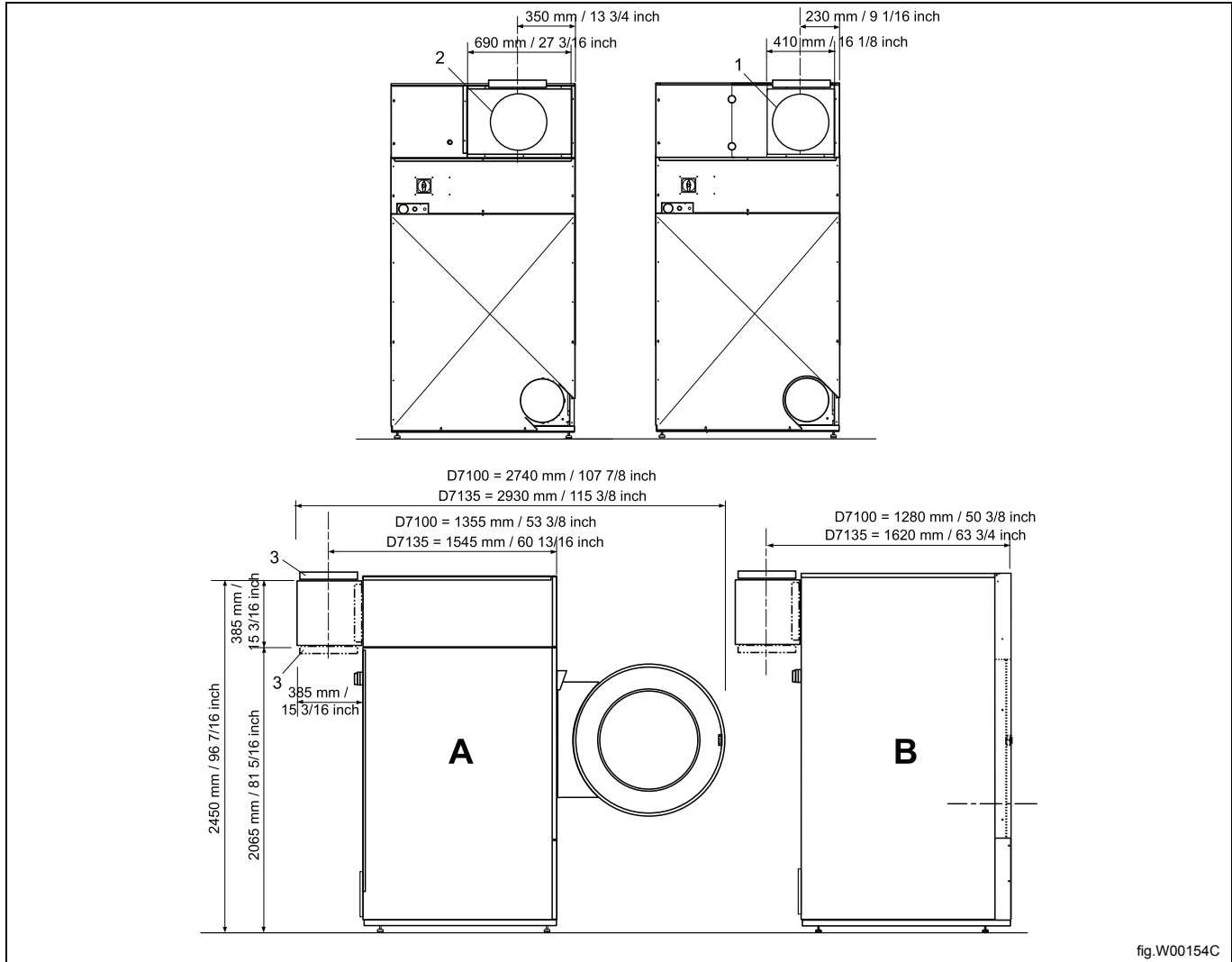



www.wascomat.com